



**BUREAU
VERITAS**



TEST REPORT

Engineering recommendation G98

Requirements for the connection of Fully Type Tested Micro-generators (up to and including 16 A per phase) in parallel with public Low Voltage Distribution Networks.

Report reference number	PVUK190111N002-R1
Date of issue	2019-09-26
Total number of pages	95
Testing laboratory name	Bureau Veritas Shenzhen Co., Ltd. Dongguan Branch
Address	No. 34, Chenwulu Section, Guantai Rd., Houjie Town, Dongguan City, Guangdong 523942, China
	 
Applicant's name	Shenzhen SOFAR SOLAR Co., Ltd.
Address	401, Building 4, AnTongDa Industrial Park, District 68, XingDong Community, XinAn Street, BaoAn District, Shenzhen, China.
Test specification	
Standard	G98/1-3:2019
Certificate	Certificate of compliance
Test report form number	TEST REPORT G98-1 VER.0
Master TRF	Bureau Veritas Shenzhen Co., Ltd. Dongguan Branch
Test item description	Grid connected photovoltaic inverter
Trademark	
Model / Type	SOFAR 1100TL, SOFAR 1600TL, SOFAR 2200TL, SOFAR 2700TL, SOFAR 3000TL
<small><i>This report is governed by, and incorporates by reference, CPS Conditions of Service as posted at the date of issuance of this report at http://www.bureauveritas.com/home/about-us/our-business/cps/about-us/terms-conditions/ and is intended for your exclusive use. Any copying or replication of this report to or for any other person or entity, or use of our name or trademark, is permitted only with our prior written permission. This report sets forth our findings solely with respect to the test samples identified herein. The results set forth in this report are not indicative or representative of the quality or characteristics of the lot from which a test sample was taken or any similar or identical product unless specifically and expressly noted. Our report includes all of the tests requested by you and the results thereof based upon the information that you provided to us. Measurement uncertainty is only provided upon request for accredited tests. You have 60 days from date of issuance of this report to notify us of any material error or omission caused by our negligence or if you require measurement uncertainty; provided, however, that such notice shall be in writing and shall specifically address the issue you wish to raise. A failure to raise such issue within the prescribed time shall constitute your unqualified acceptance of the completeness of this report, the tests conducted and the correctness of the report contents.</i></small>	



Ratings :	SOFAR 1100TL	SOFAR 1600TL	SOFAR 2200TL	SOFAR 2700TL	SOFAR 3000TL
MPP DC voltage range [V]..... :	110-450	165-450	170-500	200-500	200-500
Input DC voltage range [V]..... :	90-450		100-500		
Input DC current [A]..... :	Max.10		Max.13		
Output AC voltage [V]..... :	230V, 50/60Hz				
Output AC current [A]..... :	Max.4,5	Max.7,0	Max.9,5	Max.11,5	Max.13,0
Output power [VA]..... :	1000	1550	2100	2600	3000

Testing Location	Bureau Veritas Shenzhen Co., Ltd. Dongguan Branch
Address	No. 34, Chenwulu Section, Guantai Rd., Houjie Town, Dongguan City, Guangdong 523942, China
Tested by (name and signature).....	Dora Zhang 
Approved by (name and signature).....	James Huang 
Manufacturer's name	Shenzhen SOFAR SOLAR Co., Ltd.
Manufacturer address	401, Building 4, AnTongDa Industrial Park, District 68, XingDong Community, XinAn Street, BaoAn District, Shenzhen, China.
Factory's name	Dongguan SOFAR SOLAR Co., Ltd.
Factory address	1F - 6F, Building E, No. 1 JinQi Road, Bihu Industrial Park, Wulian Village, Fenggang Town, Dongguan City.

Document History			
Date	Internal reference	Modification / Change / Status	Revision
2019-04-18	Dora Zhang	Initial report was written	--
2019-09-26	Dora Zhang	Update the test results of "A 1.2.8 Power response to over-frequency"	R1
Supplementary information:			

Test items particulars	
Equipment mobility.....	: Permanent connection
Operating condition.....	: Continuous
Class of equipment	: Class I
Protection against ingress of water..	: IP65 according to EN 60529
Mass of equipment [kg].....	: SOFAR 1100TL, SOFAR 1600TL, SOFAR 2200TL: 11kg SOFAR 2700TL, SOFAR 3000TL: 12kg
Test case verdicts	
Test case does not apply to the test object.....	: N/A
Test item does meet the requirement.....	: P(ass)
Test item does not meet the requirement.....	: F(ail)
Testing	
Date of receipt of test item.....	: 2019-01-11 & 2019-09-22
Date(s) of performance of test.....	: 2019-01-11 to 2019-04-18 & 2019-09-22 to 2019-09-23
General remarks:	
<p>The test result presented in this report relate only to the object(s) tested. The report shall state compliance of the tested objects with the requirements of G98-1. This report must not be reproduced in part or in full without the written approval of the issuing testing laboratory.</p> <p>"(see Annex #)" refers to additional information appended to the report. "(see appended table)" refers to a table appended to the report.</p> <p>This report is to replace the earlier Test Report Ref. No. PVUK190111N002, issue by Bureau Veritas Shenzhen Co., Ltd. Dongguan Branch, on 18. Apr., 2019.</p> <p>Throughout this report a comma is used as the decimal separator.</p>	
This Test Report consists of the following documents:	
<ol style="list-style-type: none"> 1. Test Results 2. Annex No. 1 – Pictures of the unit 3. Annex No. 2 – Test equipment list 	

Copy of marking plate

SOFAR Solar Grid-tied Inverter		SOFAR Solar Grid-tied Inverter		SOFAR Solar Grid-tied Inverter	
Model No:	SOFAR 1100TL	Model No:	SOFAR 1600TL	Model No:	SOFAR 2200TL
Vmax.DC Input Voltage	450V	Vmax.DC Input Voltage	450V	Vmax.DC Input Voltage	500V
DC Input Voltage Range	90~450V	DC Input Voltage Range	90~450V	DC Input Voltage Range	100~500V
Imax.DC Input Current	10A	Imax.DC Input Current	10A	Imax.DC Input Current	13A
Isc(max.) DC Current	12A	Isc(max.) DC Current	12A	Isc(max.) DC Current	15A
Nominal Grid Voltage	230V~	Nominal Grid Voltage	230V~	Nominal Grid Voltage	230V~
Nominal AC Output Current	4.5A	Nominal AC Output Current	7A	Nominal AC Output Current	9.5A
Nominal Grid Frequency	50/60Hz	Nominal Grid Frequency	50/60Hz	Nominal Grid Frequency	50/60Hz
Nominal Output Power	1000VA	Nominal Output Power	1550VA	Nominal Output Power	2100VA
Power Factor	1 (adjustable+/-0.8)	Power Factor	1 (adjustable+/-0.8)	Power Factor	1 (adjustable+/-0.8)
Ingress Protection	IP65	Ingress Protection	IP65	Ingress Protection	IP65
Operating Temperature Range	-25°C~+60°C	Operating Temperature Range	-25°C~+60°C	Operating Temperature Range	-25°C~+60°C
Protective Class	Class I	Protective Class	Class I	Protective Class	Class I
<p>Made in China</p> <p>Manufacturer : Shenzhen SOFAR SOLAR Co.,Ltd.</p> <p>Address : 401, Building 4, An TongDa Industrial Park, District 68, XingDong Community,XinAn Street, BaoAn District, Shenzhen, China</p> <p>SAA161894</p> <p>VDE0126-1-1,VDE-AR-N4105,G98, EN50438,C10/11,AS4777,RD1699,UTE C15-712-1</p>		<p>Made in China</p> <p>Manufacturer : Shenzhen SOFAR SOLAR Co.,Ltd.</p> <p>Address : 401, Building 4, An TongDa Industrial Park, District 68, XingDong Community,XinAn Street, BaoAn District, Shenzhen, China</p> <p>SAA161894</p> <p>VDE0126-1-1,VDE-AR-N4105,G98, EN50438,C10/11,AS4777,RD1699,UTE C15-712-1</p>		<p>Made in China</p> <p>Manufacturer : Shenzhen SOFAR SOLAR Co.,Ltd.</p> <p>Address : 401, Building 4, An TongDa Industrial Park, District 68, XingDong Community,XinAn Street, BaoAn District, Shenzhen, China</p> <p>SAA161894</p> <p>VDE0126-1-1,VDE-AR-N4105,G98, EN50438,C10/11,AS4777,RD1699,UTE C15-712-1</p>	
					

SOFAR Solar Grid-tied Inverter		SOFAR Solar Grid-tied Inverter	
Model No:	SOFAR 2700TL	Model No:	SOFAR 3000TL
Vmax.DC Input Voltage	500V	Vmax.DC Input Voltage	500V
DC Input Voltage Range	100~500V	DC Input Voltage Range	100~500V
Imax.DC Input Current	13A	Imax.DC Input Current	13A
Isc(max.) DC Current	15A	Isc(max.) DC Current	15A
Nominal Grid Voltage	230V~	Nominal Grid Voltage	230V~
Nominal AC Output Current	11.5A	Nominal AC Output Current	13A
Nominal Grid Frequency	50/60Hz	Nominal Grid Frequency	50/60Hz
Nominal Output Power	2600VA	Nominal Output Power	3000VA
Power Factor	1 (adjustable+/-0.8)	Power Factor	1 (adjustable+/-0.8)
Ingress Protection	IP65	Ingress Protection	IP65
Operating Temperature Range	-25°C~+60°C	Operating Temperature Range	-25°C~+60°C
Protective Class	Class I	Protective Class	Class I
<p>Made in China</p> <p>Manufacturer : Shenzhen SOFAR SOLAR Co.,Ltd.</p> <p>Address : 401, Building 4, An TongDa Industrial Park, District 68, XingDong Community,XinAn Street, BaoAn District, Shenzhen, China</p> <p>SAA161894</p> <p>VDE0126-1-1,VDE-AR-N4105,G98, EN50438,C10/11,AS4777,RD1699,UTE C15-712-1</p>		<p>Made in China</p> <p>Manufacturer : Shenzhen SOFAR SOLAR Co.,Ltd.</p> <p>Address : 401, Building 4, An TongDa Industrial Park, District 68, XingDong Community,XinAn Street, BaoAn District, Shenzhen, China</p> <p>SAA161894</p> <p>VDE0126-1-1,VDE-AR-N4105,G98, EN50438,C10/11,AS4777,RD1699,UTE C15-712-1</p>	
			

General product information:

The Solar Inverter converts DC voltage into AC voltage.

The input and output are protected by varistors to Earth. The unit is providing EMC filtering at the PV input and output toward mains. The unit does not provide galvanic separation from input to output (transformerless). The output is switched off redundantly by the high power switching bridge and two relays. This assures that the opening of the output circuit will also operate in case of a single error.

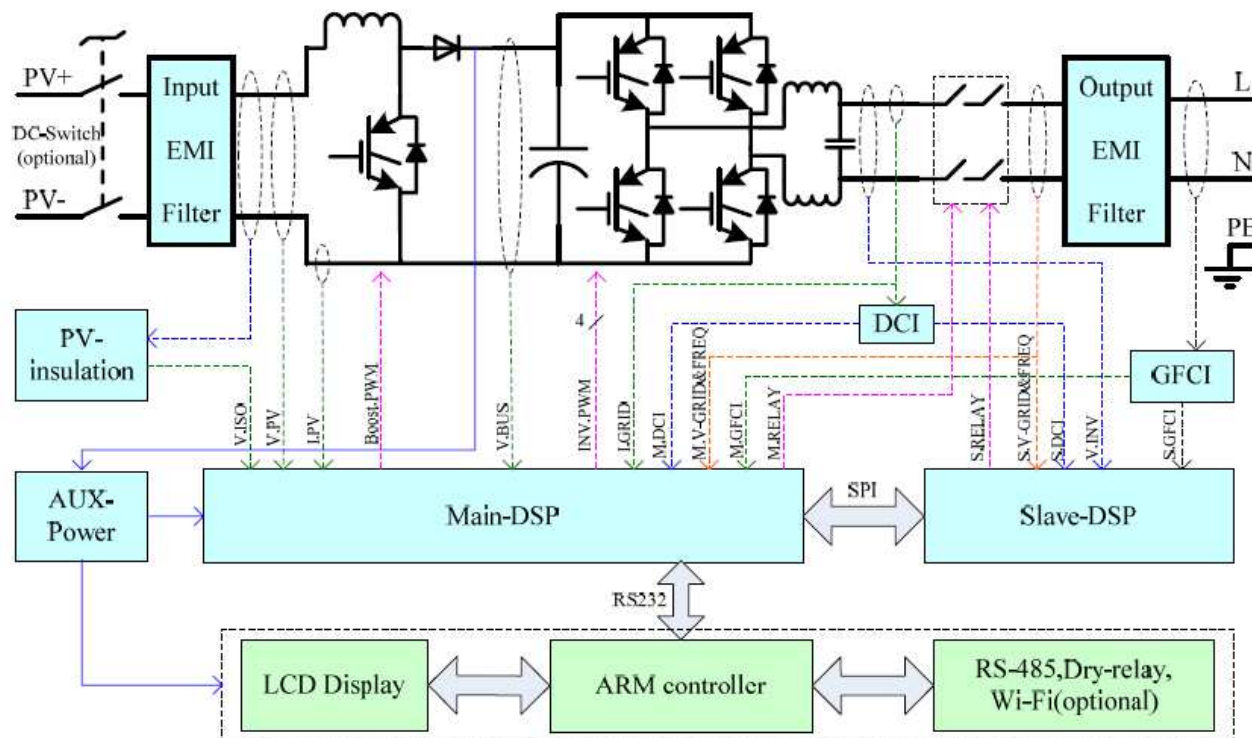

The internal control is redundant built. It consists of Microcontroller Master DSP (UC34) and Slave DSP (UC35).

The Master DSP control the relays (RYP2-RYP5) by switching signals; measures the PV voltage, PV current, Bus voltage, grid voltage, frequency, AC current with injected DC and the array insulation resistance to ground. In addition it tests the current sensors and the RCMU circuit before each start up.

The Slave DSP (UC35) is measures the grid voltage, AC current, grid frequency and residual current, also can switch off the relays (RYP2-RYP5) independently, and communicate with Master DSP (UC34) each other.

The current is measured by a current sensor. The AC current signal and the injected DC current signal are sent to the Master DSP(UC34). The Master DSP(UC34) tests and calibrates before each start up all current sensors.

The unit provides two relays in series in all output conductors. When single fault applied to one relay, alarm an error code in display panel, another redundant relay provides basic insulation maintained between the PV array and the mains. All the relays are tested before each start up.

The product was tested on:
Hardware version: V1.00
Software version: V1.00

Description of the differences of the models within a series:

The models SOFAR 1100TL, SOFAR 1600TL, SOFAR 2200TL, SOFAR 2700TL and SOFAR 3000TL are same as in hardware except the components are in the different table. Identical in software the output power just adjusted by software.

Difference table					
	SOFAR 1100TL	SOFAR 1600TL	SOFAR 2500TL	SOFAR 2700TL	SOFAR 3000TL
Boost inductor	2,6mH	2,6mH	1,9mH	1,9mH	1,9mH
Resistor (RP105, RP108 /RP189,RP109)	220ohm / 10Kohm	220ohm / 10Kohm	200ohm / 7,5Kohm	200ohm / 7,5Kohm	200ohm / 7,5Kohm
BUS capacitor (ECP1, ECP2, ECP3, ECP4)	2 pcs	2 pcs	3 pcs	3 pcs	3 or 4 pcs
Inverter inductor	3,4mH	2,3mH	2,1mH	1,5mH	1,3mH
Resistor (RP118, RP119, RC18 /RP120, RP121,RC22)	499 Ω, 200 Ω, 200 Ω	1 KΩ, 200 Ω, 100 Ω	1 KΩ, 330 Ω, 330 Ω	2 KΩ, 100 Ω, 100 Ω	2 KΩ, 100 Ω, 100 Ω
DC switch and Wi-Fi module are optional.					

All tests were performed on EUT SOFAR 3000TL. Tests of the SOFAR 3000TL not applicable for the model(s) SOFAR 1100TL, SOFAR 1600TL, SOFAR 2200TL and SOFAR 2700TL were performed on the concerned model(s) and a statement is given at the relevant test.

Engineering recommendation G98/1-3			
Clause	Requirement – Test	Result – Remark	Verdict
5	Connection Procedure		
5.1	Single Premises Connection Procedure		
5.1.1	In most instances the installation of Micro-generating Plant, the aggregate Registered Capacity of which is no greater than 16 A per phase, connected in parallel with the public Low Voltage Distribution Network, will have negligible impact on the operation of the public Low Voltage Distribution Network; as such there will be no need for the DNO to carry out detailed network studies to assess the impact of the connection. As required by the ESQCR Certificate of Exemption (2008) the Installer shall provide the DNO with all necessary information on the installation no later than 28 days after the Micro-generating Plant has been commissioned; the format and content shall be as shown in Appendix 3 Form B Installation Document.	Rely in the responsibility of the installer.	N/A
5.1.2	This procedure will not apply where an Installer plans (within the next 28 days) or has already installed (in the previous 28 days) other Micro-generating Plants in a Close Geographic Region; in this case the procedure in 5.2 shall be followed. Failure to comply with this requirement may lead to the disconnection of the Micro-generating Plant under ESQCR (26) or failure of the Micro-generating Plant to operate as intended.	Rely in the responsibility of the installer.	N/A
5.2	Multiple Premises Connection Procedure		N/A
5.2.1	In the case of projects where the proposal is to install single or multiple Micro-generators in a number of Customer Installations in a Close Geographic Region, the Installer shall discuss the installation project with the local DNO at the earliest opportunity. The DNO will need to assess the impact that these connections may have on the Distribution Network and specify conditions for connection. The initial application will need to be in a format similar to that shown in Appendix 3 Form A. Connection of the Micro-generator is only allowed after the application for connection has been approved by the DNO and any DNO works facilitating the connection have been completed. Confirmation of the commissioning of each Micro-generator will	The required wiring for the SSEG is stated in the manual. The installation relies in the responsibility of the installer.	N/A

Engineering recommendation G98/1-3			
Clause	Requirement – Test	Result – Remark	Verdict
	need to be made no later than 28 days after commissioning; the format and content shall be as shown in Appendix 3 Form B Installation Document.		
6	Certification Requirements		
6.1	Type Test Certification		P
6.1.1	Type Tested certification is the responsibility of the Manufacturer. The Manufacturer shall make available upon request a Type Test Verification Report confirming that the Micro-generator has been tested to satisfy the requirements of this EREC G98. The report shall detail the type and model of Micro-generator tested, the test conditions and results recorded. All of these details shall be included in a Type Test Verification Report. The required verification report and declaration are shown in Appendix 3 Form C. It is intended that Manufacturers of Micro-generators will use the requirements of this EREC G98 to develop type verification certification for each of their Micro-generator models.	Considered	P
6.1.2	Manufacturers of a Fully Type Tested Micro-generator should allocate a Manufacturer's reference number with the required details of the Micro-generator with the Energy Networks Association Type Test Verification Report Register.	Considered	P
6.2	Compliance		P
6.2.1	Compliance with the requirements detailed in this EREC G98 will ensure that the Micro-generator(s) is considered to be approved for connection to the DNO's Distribution Network.	Considered	P
6.2.2	The Micro-generator(s) shall conform to all relevant European Directives and should be labelled with a CE marking.	Considered	P
7	Operation and Safety		
7.1	Operational Requirements		P
7.1.1	Compliance with this EREC G98 in respect of the design, installation, operation and maintenance of a Micro-generating Plant, will ensure that the Customer is discharging their legal obligations under ESQCR 22(1)(a) and the EU Network Code on Requirements for Grid Connection of	The inverter is tested according the relevant requirements. The operational requirements in all cases rely in the responsibility of	P

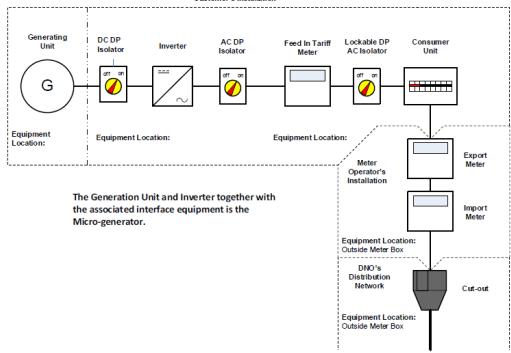
Engineering recommendation G98/1-3			
Clause	Requirement – Test	Result – Remark	Verdict
	Generators.	the user.	
7.2	Isolation		P
7.2.1	The Micro-generator(s) shall be connected via an accessible isolation switch that is capable of isolating all phases and neutral. The isolation switch shall be capable of being secured in the 'off' (isolated) position.		P
7.3	Labelling		P
7.3.1	Labelling shall be placed in accordance with EN 50438. It should be noted that the warning label does not imply a right on the Customer, Installer or maintainer to operate (remove / replace) the DNO's cut-out fuse and a note to this effect should be included on the warning label.	The required labelling is stated in the manual of the SSEG. The installation relies in the responsibility of the installer.	P
7.3.2	In addition to the warning label, this EREC G98 requires the following, up to date, information to be displayed at the Connection Point with the DNO's Distribution Network. a) A circuit diagram relevant to the installation showing the circuit wiring, including all protective devices, between the Micro-generator and the DNO's fused cut-out. This diagram should also show by whom all apparatus is owned and maintained; and b) A summary of the Interface Protection settings incorporated within the Micro-generator.	The required labelling is stated in the manual of the SSEG. The installation relies in the responsibility of the installer.	P
7.3.3	Figure 1 shows an outline example of the type of circuit diagram that will need to be displayed. Figure 1 is non-prescriptive and is for illustrative purposes only.  <p>Figure 1 – Example of the type of circuit diagram</p>	The required labelling is stated in the manual of the SSEG. The installation relies in the responsibility of the installer.	P
7.3.4	The Installer shall advise the Customer that it is the Customer's responsibility to ensure that this safety information is kept up to	See user manual	P

Engineering recommendation G98/1-3			
Clause	Requirement – Test	Result – Remark	Verdict
	date. The installation operating instructions shall contain the Manufacturer's contact details eg name, telephone number and web address.		
7.4	Maintenance & Routine Testing		P
7.4.1	Periodic testing of the Micro-generator is recommended at intervals prescribed by the Manufacturer. This information shall be included in the installation and user instructions. The method of testing and/or servicing should be included in the servicing instructions.	See user manual	P
7.5	Phase Unbalance		P
7.5.1	There is no requirement to balance phases on installations below or equal to 16 A per phase.	Less than 16A per phase	N/A
7.5.2	For multiple installations of Micro-generators (eg new housing developments), balancing the Micro-generators evenly against the load on the three phases will need to be considered by the DNO. The DNO will advise the Installer of any phase balancing requirements.	See user manual	P
8	Commissioning, Notification and Decommissioning		
8.1	General		N/A
8.1.1	The installation shall be carried out by Installers who are competent and have sufficient skills and training (complete with recognised and approved qualifications relating to the fuels used and general electrical installations) to apply safe methods of work to install a Micro-generator in compliance with this EREC G98.	Rely in the responsibility of the installer.	N/A
8.1.2	Notwithstanding the requirements of this EREC G98, the installation will be carried out to no lower a standard than that required in the Manufacturer's installation instructions.	Rely in the responsibility of the installer.	N/A
8.1.3	The information required by a DNO under an Application for Connection is shown in Appendix 3 Form A. The information required by a DNO to confirm commissioning is shown in Appendix 3 Form B.	Rely in the responsibility of the installer.	N/A
8.1.4	It is the responsibility of the Installer to ensure that the relevant information as specified in sections 5 and 6 is forwarded	Rely in the responsibility of the installer.	N/A

Engineering recommendation G98/1-3			
Clause	Requirement – Test	Result – Remark	Verdict
	to the local DNO as appropriate. The pro forma in Appendix 3 are designed to: a) simplify the connection procedure for both DNO and Micro-generator Installer; b) provide the DNO with all the information required to assess the potential impact of the Micro-generator connection on the operation of the Distribution Network; c) inform the DNO that the Micro-generator installation complies with the requirements of this EREC G98; and d) allow the DNO to accurately record the location of all Micro-generators connected to the Distribution Network.		
8.1.5	Upon receipt of a multiple premises connection application the DNO's response will be in accordance with the electricity generation standards set by the Authority for applications connecting to the Distribution Network.	Rely in the responsibility of the installer.	N/A
8.2	Commissioning		N/A
8.2.1	No parameter relating to the electrical connection and subject to type verification certification shall be modified unless previously agreed in writing between the DNO and the Customer or their agent. Customer access to such parameters shall be prevented.	Rely in the responsibility of the installer.	N/A
8.2.2	As part of the on-site commissioning tests the Installer shall carry out a functional check of the loss of mains protection, for example by removing the supply to the Micro-generator during operation and checking that the Interface Protection operates to disconnect the Micro-generator from the DNO's Distribution Network. For three phase installations this test can be achieved by opening a three phase circuit breaker or isolator and confirming that the Micro-generator has shut down. Testing for the loss of a single phase is covered in the type testing of Inverters, see section 10.2.	Rely in the responsibility of the installer.	N/A
8.3	Notification of Commissioning		N/A
8.3.1	In accordance with ESQCR and the HSE Certificate of Exemption (2008) (see Appendix 4) the Installer shall ensure that the DNO is advised of the intention to use the Micro-generator in parallel with the Distribution Network no later than 28 days (inclusive of the day of commissioning)	Rely in the responsibility of the installer.	N/A

Engineering recommendation G98/1-3			
Clause	Requirement – Test	Result – Remark	Verdict
	after commissioning the Micro-generator. Notification that the Micro-generator has been commissioned is achieved by completing an Installation Document as per Appendix 3 Form B (Installation Document), which also includes the relevant details on the Micro-generator installation required by the DNO.		
8.3.2	The Installer shall supply separate Installation Documents for each premises in which Micro-generators are installed under EREC G98. Documentation may be submitted via an agent acting on behalf of the Installer and may be submitted electronically.	Rely in the responsibility of the installer.	N/A
8.4	Notification of Changes		N/A
8.4.1	If a Micro-generator requires modification the Manufacturer must re-submit the Type Test Verification Report prior to the modification being made and the Micro-generator being recommissioned.	Rely in the responsibility of the installer.	N/A
8.4.2	The DNO shall be notified of any operational incidents or failures of a Micro-generator that affect its compliance with this EREC G98, without undue delay, after the occurrence of those incidents.	Rely in the responsibility of the installer.	N/A
8.4.3	The DNO shall have the right to request that the Customer arrange to have compliance tests undertaken after any failure, modification or replacement of any equipment that may have an impact on the Micro-generator's compliance with this EREC G98.	Rely in the responsibility of the installer.	N/A
8.5	Notification of Decommissioning		N/A
8.5.1	The Customer shall notify the DNO about the permanent decommissioning of a Micro-generator by providing the information as detailed under Appendix 3 Form D. Documentation may be submitted by an agent acting on behalf of the Customer and may be submitted electronically.	Rely in the responsibility of the installer.	N/A
9	General Technical Requirements		
9.1	Frequency withstand		P
9.1.1	The Micro-generator shall be capable of remaining connected to the Distribution Network and operating within the frequency ranges and time periods specified in Table	Considered	P

Engineering recommendation G98/1-3															
Clause	Requirement – Test	Result – Remark	Verdict												
	<p>1 unless disconnection was triggered by rate-of-change-of-frequency-type loss of mains protection.</p> <p>Table 1 – Minimum time periods for which a Micro-generator has to be capable of operating within different frequency ranges without disconnecting from the Distribution Network</p> <table border="1"> <tr> <td>47.0 Hz – 47.5 Hz</td> <td>20 seconds</td> </tr> <tr> <td>47.5 Hz – 48.5 Hz</td> <td>90 minutes</td> </tr> <tr> <td>48.5 Hz -49.0 Hz</td> <td>90 minutes</td> </tr> <tr> <td>49.0 Hz – 51.0 Hz</td> <td>Unlimited</td> </tr> <tr> <td>51.0 Hz – 51.5 Hz</td> <td>90 minutes</td> </tr> <tr> <td>51.5 Hz – 52.0 Hz</td> <td>15 minutes</td> </tr> </table>	47.0 Hz – 47.5 Hz	20 seconds	47.5 Hz – 48.5 Hz	90 minutes	48.5 Hz -49.0 Hz	90 minutes	49.0 Hz – 51.0 Hz	Unlimited	51.0 Hz – 51.5 Hz	90 minutes	51.5 Hz – 52.0 Hz	15 minutes		
47.0 Hz – 47.5 Hz	20 seconds														
47.5 Hz – 48.5 Hz	90 minutes														
48.5 Hz -49.0 Hz	90 minutes														
49.0 Hz – 51.0 Hz	Unlimited														
51.0 Hz – 51.5 Hz	90 minutes														
51.5 Hz – 52.0 Hz	15 minutes														
9.2	Rate of Change of Frequency		P												
9.2.1	With regard to the rate of change of frequency withstand capability, a Micro-generator shall be capable of staying connected to the Distribution Network and operate at rates of change of frequency up to 1.0 Hzs-1 measured over 500 ms.	Considered	P												
9.3	Limited Frequency Sensitive Mode – Overfrequency		P												
9.3.1	With regard to the Limited Frequency Sensitive Mode — Overfrequency (LFSM-O), the Micro-generator shall be capable of activating the provision of Active Power Frequency Response according to EN 50438. The GB specific standard frequency threshold shall be 50.4 Hz; the Droop setting shall be 10%. No intentional delay should be programmed to ensure that the initial delay is as short as possible with a maximum of 2 s.	Considered	P												
9.3.2	The Micro-generator will continue to reduce power with rising frequency with a Droop of 10% until 52.0 Hz, at which point the Micro-generator should disconnect.	Considered	P												
9.4	Active Power Output		P												
9.4.1	The Micro-generator shall be capable of maintaining constant output at its Registered Capacity regardless of changes in frequency, except where the output follows the changes defined in the context of paragraphs 9.3.1 and 9.4.2.	Considered	P												
9.4.2	The Micro-generator shall be capable of maintaining constant output at its	Considered	P												

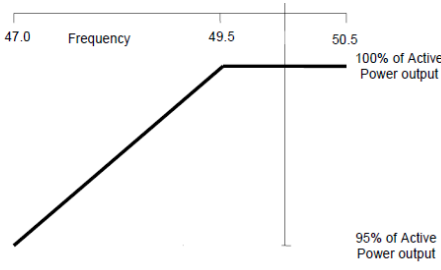
Engineering recommendation G98/1-3			
Clause	Requirement – Test	Result – Remark	Verdict
	<p>Registered Capacity regardless of changes in frequency in the range 49.5 – 50.4 Hz. Below 49.5 Hz, the power output should not drop by more than pro-rata with frequency, ie the maximum permitted requirement is 100% power at 49.5 Hz falling linearly to 95% power at 47.0 Hz as illustrated in Figure 2.</p>  <p>Figure 2 – Change in output power with falling frequency</p>		
9.4.3	<p>The Micro-generator shall be equipped with a logic interface (input port) in order to cease Active Power output within 5 s following an instruction being received from the DNO at the input port. By default the logic interface will take the form of a simple binary output that can be operated by a simple switch or contactor. When the switch is closed the Micro-generator can operate normally. When the switch is opened the Micro-generator will reduce its Active Power to zero within 5 s. The signal from the Micro-generator that is being switched can be either AC (maximum value 240 V) or DC (maximum value 110 V). The DNO may specify any additional requirements particularly regarding remote operation of this facility.</p>	Considered	P
9.5	Power Factor		P
9.5.1	<p>The power factor capability of the Micro-generator shall conform to EN 50438. When operating at Registered Capacity the Micro-generator shall operate at a power factor within the range 0.95 lagging to 0.95 leading relative to the voltage waveform unless otherwise agreed with the DNO eg for power factor improvement.</p>	Considered	P
9.6	Automatic Connection		P
9.6.1	<p>Micro-generators shall conform to EN 50438 in respect of connection and starting to generate electric power. This includes automatic reconnection where the minimum observation time shall be as</p>	Considered	P

Engineering recommendation G98/1-3																											
Clause	Requirement – Test	Result – Remark	Verdict																								
	stated in Annex A12 of EN 50438.																										
10	Interface Protection																										
10.1	General		P																								
10.1.1	The Micro-generator shall conform to the Interface Protection settings set out below (Table 2). Means shall be provided to protect the settings from unpermitted interference (eg via a password or seal).	Considered	P																								
10.1.2	The DNO is responsible under the Distribution Code for ensuring, by design, that the voltage and frequency at the Connection Point remains within statutory limits. The Interface Protection settings have been chosen to allow for voltage rise or drop within the Customer's Installation and to allow the Micro-generator to continue to operate outside of the statutory frequency range as required by the EU Network Code on Requirements for Grid Connection of Generators.	Considered	P																								
10.1.3	Interface Protection shall be installed which disconnects the Micro-generator from the DNO's Distribution Network when any parameter is outside of the settings shown in Table 2. Table 2 – Interface Protection settings <table border="1"> <thead> <tr> <th>Protection Function</th> <th>Trip Setting</th> <th>Time Delay Setting</th> </tr> </thead> <tbody> <tr> <td>U/V</td> <td>$V_{\varphi-n}^{\dagger} - 20\% = 184 \text{ V}$</td> <td>2.5 s</td> </tr> <tr> <td>O/V stage 1</td> <td>$V_{\varphi-n}^{\dagger} + 14\% = 262.2 \text{ V}$</td> <td>1.0 s</td> </tr> <tr> <td>O/V stage 2</td> <td>$V_{\varphi-n}^{\dagger} + 19\% = 273.7 \text{ V}^3$</td> <td>0.5 s</td> </tr> <tr> <td>U/F stage 1</td> <td>47.5 Hz</td> <td>20 s</td> </tr> <tr> <td>U/F stage 2</td> <td>47 Hz</td> <td>0.5 s</td> </tr> <tr> <td>O/F</td> <td>52 Hz</td> <td>0.5 s</td> </tr> <tr> <td>LoM (RoCoF)</td> <td>1.0 Hzs^{-1}</td> <td></td> </tr> </tbody> </table> <p>† A value of 230 V phase to neutral</p>	Protection Function	Trip Setting	Time Delay Setting	U/V	$V_{\varphi-n}^{\dagger} - 20\% = 184 \text{ V}$	2.5 s	O/V stage 1	$V_{\varphi-n}^{\dagger} + 14\% = 262.2 \text{ V}$	1.0 s	O/V stage 2	$V_{\varphi-n}^{\dagger} + 19\% = 273.7 \text{ V}^3$	0.5 s	U/F stage 1	47.5 Hz	20 s	U/F stage 2	47 Hz	0.5 s	O/F	52 Hz	0.5 s	LoM (RoCoF)	1.0 Hzs^{-1}		Test results see appended table.	P
Protection Function	Trip Setting	Time Delay Setting																									
U/V	$V_{\varphi-n}^{\dagger} - 20\% = 184 \text{ V}$	2.5 s																									
O/V stage 1	$V_{\varphi-n}^{\dagger} + 14\% = 262.2 \text{ V}$	1.0 s																									
O/V stage 2	$V_{\varphi-n}^{\dagger} + 19\% = 273.7 \text{ V}^3$	0.5 s																									
U/F stage 1	47.5 Hz	20 s																									
U/F stage 2	47 Hz	0.5 s																									
O/F	52 Hz	0.5 s																									
LoM (RoCoF)	1.0 Hzs^{-1}																										
10.1.4	The total disconnection time for voltage and frequency protection, including the operating time of the disconnection device, shall be the time delay setting with a tolerance of, -0s + 0.5 s.	Test results see appended table.	P																								
10.1.5	For the avoidance of doubt, where the Distribution Network voltage or frequency exceed the trip settings in Table 2, for less than the time delay setting, the Micro-generator should not disconnect from the Distribution Network.	Test results see appended table.	P																								
10.1.6	Fully Type Tested Micro-generators shall have protection settings set during	Considered	P																								

Engineering recommendation G98/1-3			
Clause	Requirement – Test	Result – Remark	Verdict
	manufacture.		
10.1.7	<p>The Manufacturer shall establish a secure way of displaying the Interface Protection setting information in one of the following ways:</p> <ul style="list-style-type: none"> • A display on a screen; • A display on a PC which can communicate with the Micro-generator and confirm that it is the correct Micro-generator by means of a serial number permanently fixed to the Micro-generator and visible on the PC screen at the same time as the settings; or • Display of all Interface Protection settings and nominal voltage and current outputs, alongside the serial number of the Micro-generator, permanently fixed to the Micro-generator. 	Considered	P
10.1.8	The provision of loose documents, documents attached to the Micro-generator by cable ties etc, or provision of data on adhesive paper based products which are not likely to survive due to fading, or failure of the adhesive, for at least 20 years is not acceptable.	Considered	P
10.1.9	In response to a protection operation the Micro-generator shall be automatically disconnected from the DNO's Distribution Network. This disconnection must be achieved preferably by the separation of mechanical contacts or alternatively by the operation of a suitably rated solid state switching device. Where a solid state switching device is used to afford disconnection of the Micro-generator, the switching device shall incorporate fail safe monitoring to check the voltage level at its output stage. In the event that the solid state switching device fails to disconnect the Micro-generator, the voltage on the output side of the switching device shall be reduced to a value below 50 V within 0.5 s of the protection and trip delay timer operation.	Considered	P
10.1.10	Where a common protection system is used to provide the protection function for multiple Micro-generators the complete installation cannot be considered to comprise Fully Type Tested Micro-generators if the protection and	Test results see appended table.	P

Engineering recommendation G98/1-3			
Clause	Requirement – Test	Result – Remark	Verdict
	connections are made up on site and so cannot be factory tested or Fully Type Tested. In accordance with Annex A1 or Annex A2 if the units or Micro-generators are specifically designed with plugs and sockets to be interconnected on site, then provided the assembly passes the function tests required in Appendix 3 Form C, the Micro-generator(s) can retain Fully Type Tested status.		
10.1.11	Once the Micro-generator has been installed and commissioned the protection settings shall only be altered following written agreement between the DNO and the Customer or their agent.	Considered	P
10.2	Loss of Mains Protection		P
10.2.1	Loss of mains protection shall be incorporated and tested as defined in the compliance type testing annex of EN 50438. Active methods which use impedance measuring techniques by drawing current pulses from or injecting AC currents into the DNO's Distribution Network are not considered to be suitable. For Micro-generators which generate on more than one phase, the loss of mains protection should be able to detect the loss of a single phase of the supply network. This should be tested during type testing and recorded in the Type Test Verification Report as per Appendix 3 Form C.	Test results see appended table.	P
10.3	Frequency Drift and Step Change Stability Test		P
10.3.1	Under normal operation of the Distribution Network, the frequency changes over time due to continuous unbalance of load and generation or can experience a step change due to the loss of a Distribution Network component which does not cause a loss of supply.	Considered	P
10.3.2	In order to ensure that such phenomena do not cause unnecessary tripping of Micro-generators, stability type tests shall be carried out.	Considered	P
10.3.3	The Rate of Change of Frequency (RoCoF) and Vector Shift values required for these tests are marginally less than the corresponding protection settings for RoCoF in Table 2 and vector shifts of up to 50°. Both stability tests shall be carried out in all cases.	Test results see appended table.	P
10.3.4	The stability tests are to be carried out as	Test results see appended	P

Engineering recommendation G98/1-3			
Clause	Requirement – Test	Result – Remark	Verdict
	per the table in Appendix 3 Form C of this document and the Micro-generator should remain connected during each and every test. The tests shall check that the Micro-generator remains stable and connected during the following scenarios: <ul style="list-style-type: none"> • RoCoF: 0.95 Hzs-1 from 49.0 Hz to 51.0 Hz on both rising and falling frequency; and • Vector shift: 50° plus from 49.5 Hz and 50° minus from 50.5 Hz. 	table.	
11	Quality of Supply		
11.1	The power quality requirements set out in EN 50438 should be met along with the 11.1 requirements described in this section of EREC G98.	Considered	P
11.2	Micro-generators are likely to be installed in large numbers on LV Distribution 11.2 Networks. They are likely to operate for long periods with no diversity between them, and adjacent Micro-generators are likely to be of the same technology. Therefore, in order to accommodate a high number of Micro-generators on a Distribution Network, procedures are specified in Annex A1 and Annex A2, which need to be applied when testing for harmonic current emissions and flicker.	Considered	P
11.3	The requirements of EN 50438 shall be met for DC injection.	Considered	P
12	Short Circuit Current Contribution		
12.1	Directly Coupled Micro-generators		P
12.1.1	The short-circuit parameters of synchronous Micro-generators shall be determined by means of a short-circuit test in accordance with EN 50438.	Considered	
12.2	Inverter Connected Micro-generators		P
12.2.1	In addition to EN 50438 Manufacturers of Inverters shall take account of the following: <ul style="list-style-type: none"> • DNOs need to understand the contribution that Inverters make to system fault levels in order to determine that they can continue to safely operate their Distribution Networks without exceeding design fault levels for switchgear and other circuit components; and 	Considered	P

Engineering recommendation G98/1-3			
Clause	Requirement – Test	Result – Remark	Verdict
	<ul style="list-style-type: none"> As the output from an Inverter reduces to zero when a short circuit is applied to its terminals, a short circuit test does not represent the worst case scenario; in most cases the voltage will not collapse to zero for a Distribution Network fault. 		
12.2.2	To address this issue a test, which ensures that at least 10% of nominal voltage remains and which allows the Micro-generator to feed into a load with an X to R ratio of 2.5, is specified as detailed in Annex A1.	Considered	P
Annex A1 Requirements for Type Testing of Inverter Connected Micro-generators			
A 1.1	<p>General</p> <p>This Annex describes a methodology for obtaining type certification or type verification for Micro-generators which are connected to the Distribution Network via an Inverter.</p> <p>The compliance testing annex of EN 50438 should be complied with except where alternative requirements are detailed in this Annex.</p>	Considered	P
A 1.2	<p>Type Verification Functional Testing of the Interface Protection</p> <p>Type testing is the responsibility of the Manufacturer.</p> <p>The type testing can be done by the Manufacturer of an individual component or by an external test house or by the supplier of the complete system, or any combination of them as appropriate.</p> <p>The type testing will verify that the operation of the Interface Protection shall result:</p> <p>a) in the safe disconnection of the Micro-generator from the DNO's Distribution Network in the event that the protection settings specified in Table 2 are exceeded; and</p> <p>b) in the Micro-generator remaining connected to the DNO's Distribution Network while Distribution Network conditions are:</p> <p>1) within the envelope specified by the settings plus and minus the tolerances specified for equipment operation in Table</p>	<p>Considered</p> <p>Test results see appended table.</p>	P

Engineering recommendation G98/1-3			
Clause	Requirement – Test	Result – Remark	Verdict
	<p>2; and</p> <p>2) within the time delay settings specified in Table 2.</p> <p>Wherever possible the type testing of a Micro-generator designed for a particular type of prime mover should be proved under normal conditions of operation for that technology (unless otherwise noted).</p>		
A 1.2.1	<p>Disconnection times</p> <p>The minimum trip time delay settings, for over / under voltage, over / under frequency and loss of mains tests below, are presented in Table 2.</p> <p>For over / under voltage, over / under frequency and loss of mains tests, reconnection shall be checked as detailed below.</p>	Test results see appended table.	P
A 1.2.2	<p>Over / Under Voltage</p> <p>In addition to the EN 50438 over / under voltage tests the tests in this paragraph shall be undertaken.</p> <p>The Interface Protection shall be tested by operating the Controller in parallel with a variable AC test supply, as an example see Figure A1.1. Correct protection and ride-through operation shall be confirmed. The set points for over and under voltage at which the Interface Protection disconnects from the supply will be established by varying the AC supply voltage. The disconnect sequence should be initiated when the network conditions mean the protection should trip in accordance with the settings in Table 2, otherwise normal operation should continue.</p>	Test results see appended table.	P
A 1.2.3	<p>Over / Under Frequency</p> <p>In addition to the EN 50438 over / under frequency tests the tests in this paragraph shall be undertaken into account.</p> <p>The Micro-generator shall be tested by operating in parallel with a low impedance, variable frequency test supply system, see figure A1.2. Correct protection and ride-through operation should be confirmed during operation of the Micro-generator. The set points for over and under frequency at which the Micro-generator disconnects from the supply will be established by varying the test supply frequency.</p>	Test results see appended table.	P

Engineering recommendation G98/1-3			
Clause	Requirement – Test	Result – Remark	Verdict
A 1.2.4	<p>Loss of Mains Protection</p> <p>The tests should be carried out in accordance with BS EN 62116 and a subset of results should be recorded as indicated in the Protection – Loss of Mains test section of the Type Test Verification Report, Appendix 3 Form C.</p>	Test results see appended table.	P
A 1.2.5	<p>Reconnection</p> <p>Further tests will confirm that once the AC supply voltage and frequency have returned to be within the stage 1 settings specified in Table 2 following an automatic protection trip operation there is a minimum time delay of 20 s before the Micro-generator output is restored (ie before the Micro-generator automatically reconnects to the Distribution Network).</p>	Test results see appended table.	P
A 1.2.6	<p>Frequency Drift and Step Change Stability test</p> <p>The tests will be carried out using the same circuit as specified in A1.2.3 above and following confirmation that the Micro-generator has passed the under and over frequency trip tests and the under and over frequency stability tests.</p>	Test results see appended table.	P
A 1.2.7	<p>Active power feed-in at under-frequency</p> <p>EN 50438 shall be complied with in respect of active power feed-in at under-frequency.</p>	Test results see appended table.	P
A 1.2.8	<p>Power response to over-frequency</p> <p>EN 50438 shall be complied with in respect of power response to over-frequency using a specific standard frequency threshold of 50.4 Hz and a Droop setting of 10%.</p>	Test results see appended table.	P
A 1.3	POWER QUALITY	Test results see appended table.	P
A 1.3.1	<p>Harmonics</p> <p>The tests should be carried out as specified in BS EN 61000-3-2 and can be undertaken with a fixed source of energy at two power levels firstly between 45 and 55% and at 100% of Registered Capacity. The test must be carried out with a minimum of 2 kW of rated Micro-generators. Where an individual Micro-generator is smaller than 2 kW it should be tested as a group. However, where a Micro-generator is designed to be installed singly in an installation then this can be tested alone, for example a domestic CHP</p>	Test results see appended table.	P

Engineering recommendation G98/1-3			
Clause	Requirement – Test	Result – Remark	Verdict
	<p>unit. The maximum group size for the test is 3.68 kW.</p> <p>The results for all Micro-generators should be normalised to a rating of 3.68 kW. The Micro-generator or group shall meet the harmonic emissions of Table 1 in BS EN 61000-3-2 with a scaling factor applied as follows for each harmonic current:</p> <p>BS EN 61000-3-2 Table 1 current limit × rating of Micro-generator being tested (kW) per phase / 3.68</p>		
A 1.3.2	<p>Power Factor</p> <p>The test should be undertaken as laid out in EN 50438 with the following three test voltages 230 V –6%, 230V and 230 V +10%.</p>	Test results see appended table.	P
A 1.3.3	<p>Voltage Flicker</p> <p>The test must be carried out with a minimum of 2 kW of rated Micro-generators. Where an individual Micro-generator is smaller than 2 kW it should be tested as a group. However, where a Micro-generator is designed to be installed singly in an installation then this can be tested alone, for example a domestic CHP unit. The maximum group size for the test is 3.68 kW.</p> <p>The Micro-generator or group shall meet the required d_{max}, d_c, $d(t)$, P_{st}, P_{lt} requirements of BS EN 61000-3-3 with a scaling factor applied as follows for each voltage change component.</p> <p>d_{max}, d_c, $d(t)$, P_{st}, P_{lt} × rating of Micro-generator being tested (kW) per phase / 3.68</p> <p>The results for groups of Micro-generators should be normalised to a rating of 3.68 kW and to the standard source impedance. Single Micro-generators need to be normalised to the standard source impedance, these normalised results need to conform to the limits set out in the Type Test Verification Report, Appendix 3 Form C.</p> <p>For voltage change and flicker measurements the following simplified formula is to be used to convert the measured values to the normalised values where the power factor of the Micro-generator output is 0.98 or above. Where it is less than 0.98 then compliance with the</p>	Test results see appended table.	P

Engineering recommendation G98/1-3			
Clause	Requirement – Test	Result – Remark	Verdict
	full requirements of BS EN 61000-3-3 is required.		
A 1.3.4	DC Injection for Inverters DC injection compliance testing in EN 50438 shall be applicable to all Inverter connected Micro-generators regardless of connection configuration.	Test results see appended table.	P
A 1.3.5	Short Circuit Current Contribution for Inverters Inverter connected Micro-generators generally have small short circuit fault contributions, however, DNOs need to understand the contribution that they make to system fault levels in order to determine that they can continue to safely operate without exceeding design fault levels for switchgear and other circuit components. The following type tests shall be carried out and the results noted in the Type Test Verification Report, Appendix 3 Form C.	Test results see appended table.	P
A 1.3.6	Self-Monitoring - Solid State Disconnection Some Micro-generators include solid state switching devices to disconnect from the DNO's Distribution Network. In this case 10.1.9 requires the control equipment to monitor the output stage of the Micro-generator to ensure that in the event of a protection initiated trip the output voltage is either disconnected completely or reduced to a value below 50 V AC. This shall be verified either by self-certification by the Manufacturer, or additional material shall be presented to the tester sufficient to allow an assessment to be made.	A Disconnection device with mechanical separation in the use of two relays in series in line and neutral are provided in the SSEG.	P
A 1.3.7	Electromagnetic Compatibility (EMC) All equipment shall conform to the generic EMC standards: BS EN61000-6-3: Electromagnetic Compatibility, Generic Emission Standard; and BS EN61000-6-1: Electromagnetic Compatibility, Generic Immunity Standard.	See Annex 1 EMC test report.	P
Annex A2 Requirements for Type Testing of Synchronous Micro-generators			
A 2.1	General The compliance testing annex of EN 50438 should be complied with except where alternative requirements are detailed in this	The SSEG is a photovoltaic inverter.	N/A

Engineering recommendation G98/1-3			
Clause	Requirement – Test	Result – Remark	Verdict
	Annex.		
A 2.2	<p>Type Verification Functional Testing of the Interface Protection</p> <p>Type testing is the responsibility of the Manufacturer.</p> <p>The type testing can be done by the Manufacturer of an individual component, by an external test house or by the supplier of the complete system, or any combination of them as appropriate.</p> <p>The type testing will verify that the operation of the Interface Protection shall result:</p> <p>a) in the safe disconnection of the Micro-generator from the DNO's Distribution Network in the event that the protection settings specified in Table 2 are exceeded; and</p> <p>b) in the Micro-generator remaining connected to the DNO's Distribution Network while Distribution Network conditions are: 1) within the envelope specified by the settings plus and minus the tolerances specified for equipment operation in Table 2; and</p> <p>2) within the time delay settings specified in Table 2.</p>	The SSEG is a photovoltaic inverter.	N/A
A 2.2.1	<p>Disconnection times</p> <p>The minimum trip time delay settings, for over / under voltage, over / under frequency and loss of mains tests below, are presented in Table 2.</p> <p>For over / under voltage, over / under frequency and loss of mains tests, reconnection shall be checked as detailed below.</p>	The SSEG is a photovoltaic inverter.	N/A
A 2.2.2	<p>Over / Under Voltage</p> <p>In addition to the EN 50438 over / under voltage tests the tests in this paragraph shall be undertaken.</p> <p>The Interface Protection shall be tested by operating the Controller in parallel with a variable AC test supply, as an example see Figure A2.1. Correct protection and ride-through operation shall be confirmed. The set points for over and under voltage at which the Interface Protection disconnects from the supply will be established by varying the AC supply voltage. The</p>	The SSEG is a photovoltaic inverter.	N/A

Engineering recommendation G98/1-3			
Clause	Requirement – Test	Result – Remark	Verdict
	disconnect sequence should be initiated when the network conditions of Table 2 are met, otherwise normal operation should continue.		
A 2.2.3	<p>Over / Under Frequency</p> <p>In addition to the EN 50438 over / under frequency tests the tests in this paragraph shall be undertaken into account.</p> <p>The Interface Protection shall be tested by operating the Controller in parallel with a low impedance, variable frequency test supply system, as an example see Figure A2.2. Correct protection and ride-through operation should be confirmed during the test. The set points for over and under frequency at which the Interface Protection disconnects from the supply will be established by varying the test supply frequency.</p>	The SSEG is a photovoltaic inverter.	N/A
A 2.2.4	<p>Loss of Mains Protection</p> <p>The test described in EN 50438 should be completed at 10%, 55%, and 100% of the Registered Capacity. In both cases a subset of results should be recorded as indicated in the Protection – Loss of Mains test section of the Type Test Verification Report, Appendix 3 Form C.</p>	The SSEG is a photovoltaic inverter.	N/A
A 2.2.5	<p>Reconnection</p> <p>Further tests will confirm that once the AC supply voltage and frequency have returned to be within the stage 1 settings specified in Table 2 following an automatic protection trip operation there is a minimum time delay of 20 s before the Micro-generator output is restored (ie before the Micro-generator automatically reconnects to the Distribution Network).</p>	The SSEG is a photovoltaic inverter.	N/A
A 2.2.6	<p>Frequency Drift and Step Change Stability test</p> <p>The tests will be carried out using the same circuit as specified in A.2.2.3 above and following confirmation that the Micro-generator has passed the under and over frequency trip tests and the under and over frequency stability tests.</p>	The SSEG is a photovoltaic inverter.	N/A
A 2.2.7	<p>Active power feed-in at under-frequency</p> <p>EN 50438 shall be complied with in respect of active power feed-in at under-frequency.</p>	The SSEG is a photovoltaic inverter.	N/A
A 2.2.8	Power response to over-frequency	The SSEG is a	N/A

Engineering recommendation G98/1-3			
Clause	Requirement – Test	Result – Remark	Verdict
	EN 50438 shall be complied with in respect of power response to over-frequency using a specific standard frequency threshold of 50.4 Hz and a Droop setting of 10%.	photovoltaic inverter.	
A 2.3	POWER QUALITY	The SSEG is a photovoltaic inverter.	N/A
A 2.3.1	<p>Harmonics</p> <p>The tests should be carried out as specified in BS EN 61000-3-2 and can be undertaken with a fixed source of energy at two power levels firstly between 45 and 55% and at 100% of Registered Capacity.</p> <p>The test must be carried out with a minimum of 2 kW of rated Micro-generators. Where an individual Micro-generator is smaller than 2 kW it should be tested as a group. However, where a Micro-generator is designed to be installed singly in an installation then this can be tested alone, for example a domestic CHP unit. The maximum group size for the test is 3.68 kW.</p>	The SSEG is a photovoltaic inverter.	N/A
A 2.3.2	<p>Power Factor</p> <p>The test should be undertaken as laid out in EN 50438 with the following three test voltages 230 V –6%, 230V and 230 V +10%.</p>	The SSEG is a photovoltaic inverter.	N/A
A 2.3.3	<p>Voltage Flicker</p> <p>The test must be carried out with a minimum of 2 kW of rated Micro-generators. Where an individual Micro-generator is smaller than 2 kW it should be tested as a group. However, where a Micro-generator is designed to be installed singly in an installation then this can be tested alone, for example a domestic CHP unit. The maximum group size for the test is 3.68 kW.</p> <p>The Micro-generator or group shall meet the required d_{max}, d_c, $d(t)$, P_{st}, P_{lt} requirements of BS EN 61000-3-3 with a scaling factor applied as follows for each voltage change component.</p> <p>d_{max}, d_c, $d(t)$, P_{st}, $P_{lt} \times$ rating of Micro-generator being tested (kW) per phase / 3.68</p> <p>The results for groups of Micro-generators should be normalised to a rating of 3.68 kW and to the standard source impedance. Single Micro-generators need to be</p>	The SSEG is a photovoltaic inverter.	N/A

Engineering recommendation G98/1-3			
Clause	Requirement – Test	Result – Remark	Verdict
	<p>normalised to the standard source impedance, these normalised results need to conform to the limits set out in the Type Test Verification Report, Appendix 3 Form C.</p> <p>For voltage change and flicker measurements the following simplified formula is to be used to convert the measured values to the normalised values where the power factor of the Micro-generator output is 0.98 or above. Where it is less than 0.98 then compliance with the full requirements of BS EN 61000-3-3 is required.</p>		
A 2.3.4	<p>Short Circuit Current Contribution for Directly Coupled technology</p> <p>DNOs need to understand the contribution a Micro-generator makes to system fault levels in order to determine that they can continue to safely operate without exceeding design fault levels for switchgear and other circuit components.</p> <p>The tests in EN 50438 shall apply.</p> <p>For rotating machines and linear piston machines the test should produce a 0 – 2 s plot of the short circuit current as seen at the Micro-generator terminals.</p>	The SSEG is a photovoltaic inverter.	N/A
A 2.3.5	<p>Electromagnetic Compatibility (EMC)</p> <p>All equipment shall conform to the generic EMC standards: BS EN61000-6-3: Electromagnetic Compatibility, Generic Emission Standard; and BS EN61000-6-1: Electromagnetic Compatibility, Generic Immunity Standard.</p>	The SSEG is a photovoltaic inverter.	N/A

G98-1/1 Test Results:

A1 Common Directly Coupled Connected SSEG Requirements

A1.2 Type Verification Functional Testing of the Interface Protection Functional safety - fault condition tests according DIN V VDE V 0126-1-1								P
ambient temperature [°C] :		23,8						
model/type of power supply :		DC : 62150H-1000S AC : 61512						
manufacturer of power supply :		Chroma						
rated markings of power supply :		DC: 0-1000V, 15kW AC: 0-300V, 18kW						
component No.	fault	test condition		test time	fuse No.	fault condition		result
		AC	DC			AC	DC	
PV voltage detect UC1C Pin 9	Open	230V 12,63A	450V 6,62A	2 Min.	--	230V 0,17A	450V 0,02A	PV inverter disconnected from grid immediately, error message: ID09. (PV voltage over range)
PV current detect UC1B Pin 5	Open	230V 12,63A	450V 6,6A	2 Min.	--	230V 0,16A	450V 0,02A	PV inverter disconnected from grid immediately, error message: ID14. (PV current over range)
GFCI detect UC2D Pin 12-13	Short	230V 12,63A	450V 6,62A	2 Min.	--	230V 0,16A	450V 0,02A	PV inverter disconnected from grid immediately, error message: ID12. (GFCI fault)
GFCI detect UC2C Pin 10	Short	230V 12,63A	450V 6,62A	2 Min.	--	230V 0,16A	450V 0,02A	PV inverter disconnected from grid immediately, error message: ID52. (GFCI fault)
Grid voltage detect UC2A Pin 3	Open	230V 12,64A	450V 6,67A	2 Min.	--	230V 0,17A	450V 0,02A	PV inverter disconnected from grid immediately, error message: ID15. (Grid current or voltage over range)
Grid voltage detect RC17	Open	230V 12,63A	450V 6,62A	2 Min.	--	230V 0,17A	450V 0,01A	PV inverter disconnected from grid immediately, error message: ID02, ID49, ID70. (Grid current or voltage under range)
Grid voltage detect RC25	Open	230V 12,64A	450V 6,62A	2 Min.	--	230V 0,18A	450V 0,01A	PV inverter disconnected from grid immediately, error message: ID55. (Relay fault)
Bus voltage detect RP3	Open	230V 12,61A	450V 6,63A	2 Min.	--	230V 0,6A	450V 0,02A	PV inverter disconnected from grid immediately, error message: ID23. (Bus voltage zero fault)
Bus voltage detect UC1A Pin2-3	Short	230V 12,56A	450V 6,65A	2 Min.	--	230V 0,17A	450V 0,02A	PV inverter disconnected from grid immediately, error message: ID66. (Bus voltage over range)

component No.	fault	test condition		test time	fuse No.	fault condition		result
		AC	DC			AC	DC	
Bus voltage detect RC82	Short	230V 12,56A	450V 6,69A	2 Min.	--	230V 0,16A	450V 0,02A	PV inverter disconnected from grid immediately, error message: ID25. (Bus voltage under range)
ISO detect RC105	Open before start	230V 0,17A	450V 0,18A	2 Min.	--	230V 0,17A	450V 0,02A	PV inverter can not start up, error message: ID56. (ISO fault)
AC current detect RC22	Open	230V 12,56	450V 6,68	2 Min.	--	230V 0,17A	450V 0,02A	PV inverter disconnected from grid immediately, error message: ID15. (AC current over range), QP2, QP6, QP9, RP26, RP28, RP11 damaged.
AC current detect RC21	Open	230V 12,62A	450V 6,63A	2 Min.	--	230V 0,16A	450V 0,02A	PV inverter disconnected from grid immediately, error message: ID15. (AC current over range).
DC current detect RC33	Open	230V 12,67A	450V 6,69A	2 Min.	--	230V 0,17A	450V 0,02A	PV inverter disconnected from grid immediately, error message: ID28. (DC current over range).
DC current detect RC37	Open	230V 12,54A	450V 6,67A	2 Min.	--	230V 0,17A	450V 0,02A	PV inverter disconnected from grid immediately, error message: ID28. (DC current over range).
DC current detect RC42	Open	230V 12,62A	450V 6,66A	2 Min.	--	230V 0,16A	450V 0,02A	PV inverter disconnected from grid immediately, error message: ID51. (DC current fault).
AC current detect RC61	Open	230V 12,66A	450V 6,7A	2 Min.	--	230V 0,16A	450V 0,02A	PV inverter disconnected from grid immediately, error message: ID15, ID65. (AC voltage or current over range).
AC current detect RC80	Open	230V 12,67A	450V 6,8A	2 Min.	--	230V 0,16A	450V 0,02A	PV inverter disconnected from grid immediately, error message: ID15, ID65. (AC voltage or current over range).
GFCI detect RP70	Open	230V 12,63A	450V 6,66A	2 Min.	--	230V 0,16A	450V 0,02A	PV inverter disconnected from grid immediately, error message: ID12. (GFCI fault).
GFCI detect RP80	Open	230V 12,63A	450V 6,66	2 Min.	--	230V 0,16A	450V 0,02A	PV inverter disconnected from grid immediately, error message: ID12. (GFCI fault).
GFCI detect UP7A Pin2-3	Short	230V 12,56A	450V 6,67A	2 Min.	--	230V 0,17A	450V 0,02A	PV inverter disconnected from grid immediately, error message: ID12. (GFCI fault).
PV voltage detect RP115	Open	230V 12,62A	450V 6,67A	2 Min.	--	230V 0,16A	450V 0,02A	PV inverter disconnected from grid immediately, no display, and reconnect to grid, error message: ID56. (ISO fault).

component No.	fault	test condition		test time	fuse No.	fault condition		result
		AC	DC			AC	DC	
PV voltage detect RP115	Short	230V 12,63A	450V 6,63A	2 Min.	--	230V 0,16A	450V 0,02A	PV inverter disconnected from grid immediately, error message: ID09. (PV voltage over range)
ISO detect RP99	Open before start	230V 0,16A	450V 0,02A	2 Min.	--	230V 0,16A	450V 0,02A	PV inverter can not start up, error message: ID56. (ISO fault).
Relay detect RYP2 Pin3-4	Short before start	230V 0,16A	450V 0,02A	2 Min.	--	230V 016A	450V 0,02A	PV inverter can not start up, error message: ID55, ID77. (Relay fault).
Relay detect RYP3 Pin3-4	Short before start	230V 0,16A	450V 0,02A	2 Min.	--	230V 0,16A	450V 0,02A	PV inverter can not start up, error message: ID55, ID77. (Relay fault).
Relay detect RYP4 Pin3-4	Short before start	230V 0,16A	450V 0,02A	2 Min.	--	230V 0,16A	450V 0,02A	PV inverter can not start up, error message: ID55, ID77. (Relay fault).
Relay detect RYP5 Pin3-4	Short before start	230V 0,16A	450V 0,02A	2 Min.	--	230V 0,16A	450V 0,02A	PV inverter can not start up, error message: ID55, ID77. (Relay fault).
Grid voltage detect RP150	Open	230V 0,62A	450V 6,67A	2 Min.	--	230V 0,16A	450V 0,02A	PV inverter disconnected from grid immediately, error message: ID02. (Grid voltage under range)
Grid voltage detect RP150	Short	230V 12,64A	450V 6,66A	2 Min.	--	230V 0,16A	450V 0,02A	PV inverter disconnected from grid immediately, error message: ID01. (Grid voltage over range)
Grid voltage detect RP135	Short	230V 12,64A	450V 6,67A	2 Min.	--	230V 0,16A	450V 0,02A	PV inverter disconnected from grid immediately, error message: ID01. (Grid voltage over range)
Grid voltage detect RP135	Open	230V 12,61A	450V 6,66A	2 Min.	--	230V 0,16A	450V 0,02A	PV inverter disconnected from grid immediately, error message: ID02. (Grid voltage under range)
Loss of control CC100	Short	230V 12,61A	450V 6,67A	2 Min.	--	230V 0,16A	450V 0,02A	PV inverter disconnected from grid immediately, error message: DSP communicate fail
Loss of control XLC	Short	230V 12,63A	450V 6,65A	2 Min.	--	230V 0,16A	450V 0,02A	PV inverter disconnected from grid immediately, error message: DSP communicate fail
Communication microcontroller defect UC34 Pin 31	Open	230V 12,64A	450V 6,66A	2 Min.	--	230V 0.16A	450V 0.02A	PV inverter disconnected from grid immediately, error message: ID 53 (SPI Communication fault)

component No.	fault	test condition		test time	fuse No.	fault condition		result
		AC	DC			AC	DC	
Communication microcontroller defect UC34 Pin 37	Open	230V 12,64A	450V 6,66A	2 Min.	--	230V 0.17A	450V 0.02A	PV inverter disconnected from grid immediately, error message: ID 53 (SPI Communication fault)
Communication microcontroller defect UC34 Pin 44	Open	230V 12,63A	450V 6,66A	2 Min.	--	230V 0.17A	450V 0.02A	PV inverter disconnected from grid immediately, error message: ID 53 (SPI Communication fault)
Communication microcontroller defect UC34 Pin 47	Open	230V 12,64A	450V 6,67A	2 Min.	--	230V 0.17A	450V 0.02A	PV inverter disconnected from grid immediately, error message: ID 53 (SPI Communication fault)

The errors in the control circuit simulate that the safety is even ensured during single fault.

The tests had been performed on the SOFAR 3000TL is valid for the SOFAR 1100TL, SOFAR 1600TL, SOFAR 2200TL and SOFAR 2700TL, since it is same as in hardware and just power derated by software.

The results refer to the original test report PVUK140508N005 issued by Bureau Veritas Shenzhen Co., Ltd. Dongguan Branch, dated on Jul. 22, 2014.

Operating Range: This test should be carried out as specified in EN 50438 D.3.1.				P
Setting values	Over-voltage [V]:		253,0	
	Under-voltage [V]:		195,5	
	Over-frequency [Hz]:		52,00	
	Under-frequency [Hz]:		47,50	
<ul style="list-style-type: none"> - Test 1: U = 195,5 V; f = 47,5 Hz; P = 1,00 Sn; cosφ = 1; at least 90 mins - Test 2: U = 253,0 V; f = 51,5 Hz; P = 1,00 Sn; cosφ = 1; at least 90 mins - Test 2: U = 253,0 V; f = 52,0 Hz; P = 1,00 Sn; cosφ = 1; at least 15 mins 				
Test sequence	Voltage [V]	Frequency [Hz]	Output power [W]	Cos φ [1]
1	195,59	47,5	2874,69	0,996
2	253,11	51,5	2865,06	0,996
3	252,99	52,0	2884,71	0,994
<p>Note:</p> <p>During the tests the interface protection was disabled.</p> <p>Operation at reduced power is allowed during test 1, equal to the maximum power that can be supplied on reaching the maximum output current limit ($P \geq 0,85 S_n$).</p> <p>During the sequence of test 2, automatic adjustment to reduce power in the case of over-frequency was disabled.</p> <p>The tests had been performed on the SOFAR 3000TL is valid for the SOFAR 1100TL, SOFAR 1600TL, SOFAR 2200TL and SOFAR 2700TL, since it is same as in hardware and just power derated by software.</p>				

A1.2.2 Over / Under Voltage						P
The test procedure in Annex A.1.2.2 (Inverter connected) or Annex A2 A.2.2.2 (Synchronous).						
Single Phase / Phase 1						
Function	Setting		Trip test		No trip test	
	Voltage	Time delay	Voltage	Time delay	Voltage / time	Confirm no trip
U/V	184,0V	2,5s	184,0V	2,540s	188V / 3,5s	No trip
					180V / 2,48s	No trip
O/V stage 1	262,2V	1,0s	262,0V	1,030s	258,2V / 2,0s	No trip
O/V stage 2	273,7V	0,5s	272,5V	0,523s	269,7V / 0,98s	No trip
					277,7V / 0,48s	No trip
Note:						
The total disconnection time for voltage and frequency protection, including the operating time of the disconnection device, shall be the time delay setting with a tolerance of, -0s + 0.5 s.						
The Voltage required to trip is the setting ± 3.45 V. The time delay can be measured at a larger deviation than the minimum required to operate the protection. The No trip tests need to be carried out at the setting ± 4 V and for the relevant times as shown in the table above to ensure that the protection will not trip in error.						
The tests had been performed on the SOFAR 3000TL is valid for the SOFAR 1100TL, SOFAR 1600TL, SOFAR 2200TL and SOFAR 2700TL, since it is same as in hardware and just power derated by software.						

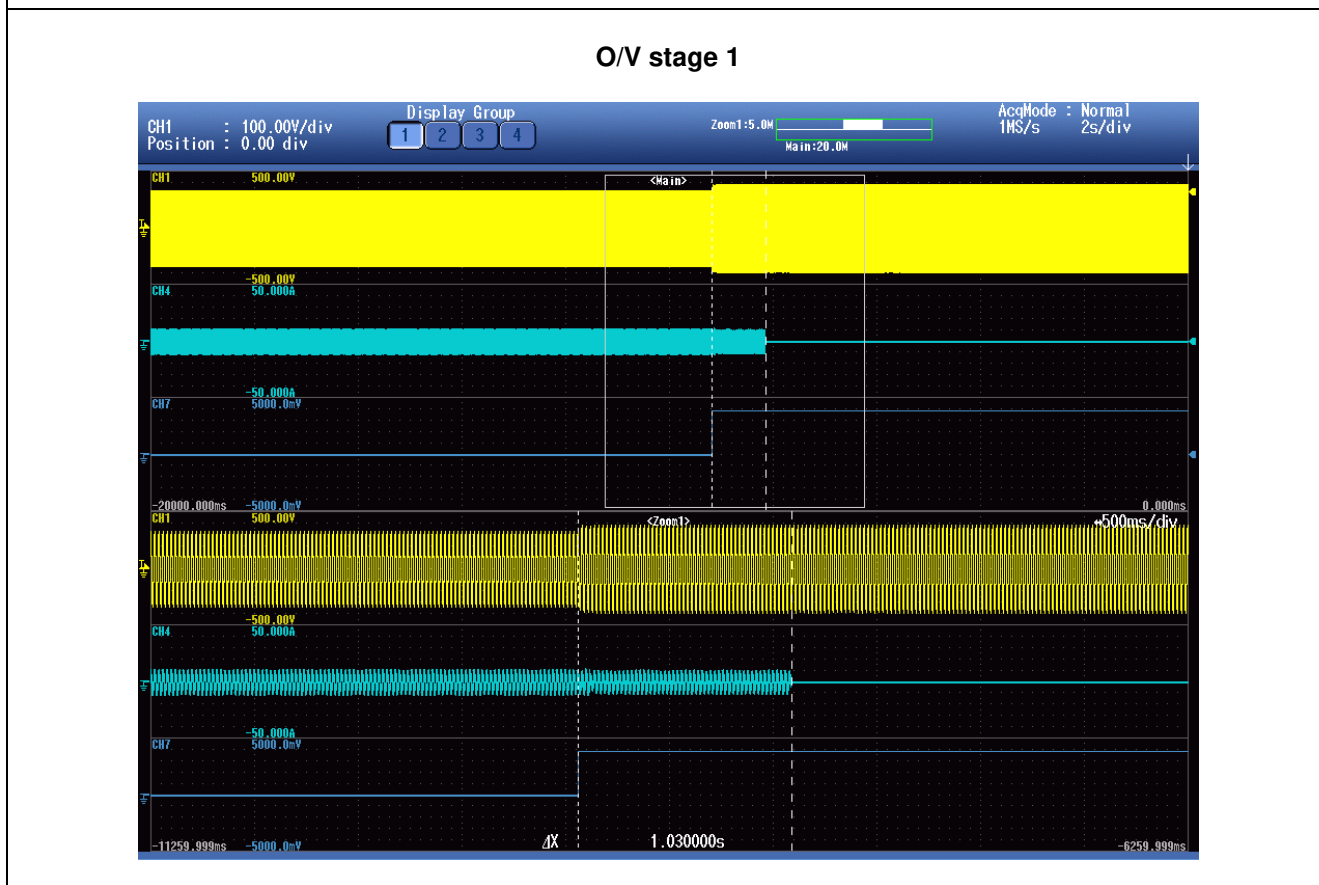
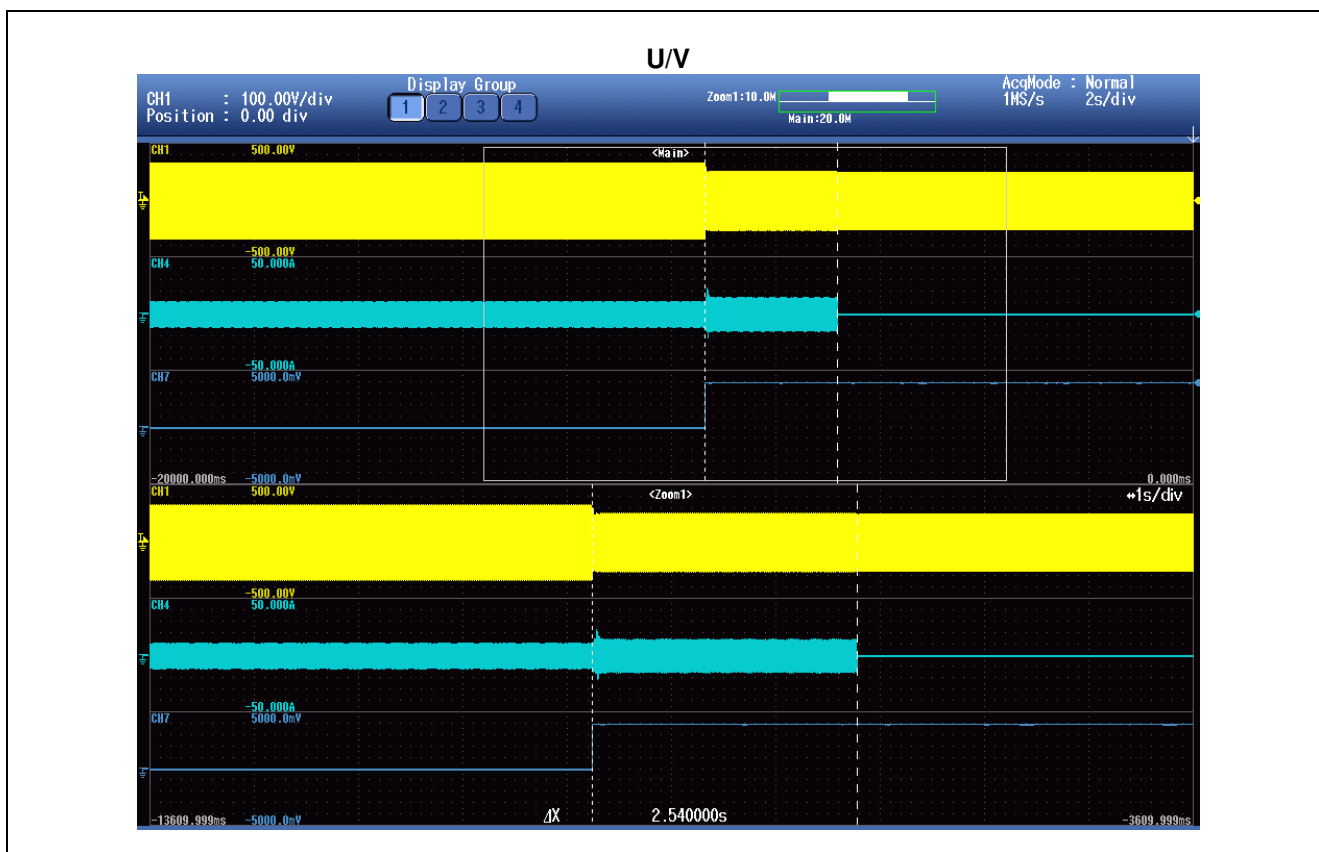

O/V stage 2



A1.2.3 Over / Under Frequency The test procedure in Annex A.1.2.3 (Inverter connected) or Annex A2 A.2.2.3 (Synchronous).						P
Function	Setting		Trip test		No trip test	
	Frequency	Time delay	Frequency	Time delay	Frequency / time	Confirm no trip
U/F stage 1	47,5Hz	20s	47,5Hz	20,140s	47,7Hz / 25s	No trip
U/F stage 2	47Hz	0,5s	47Hz	0,541s	47,2Hz / 19,98s	No trip
					46,8 Hz / 0,48s	No trip
O/F	52Hz	0,5s	52Hz	0,538s	51,8Hz / 89,98s	No trip
					52,2 Hz / 0,48s	No trip

Note:

The total disconnection time for voltage and frequency protection, including the operating time of the disconnection device, shall be the time delay setting with a tolerance of, -0s + 0.5 s.

For frequency trip tests the frequency required to trip is the setting ± 0.1 Hz. In order to measure the time delay a larger deviation than the minimum required to operate the protection can be used. The "No trip tests" need to be carried out at the setting ± 0.2 Hz and for the relevant times as shown in the table above to ensure that the protection will not trip in error.

The tests had been performed on the SOFAR 3000TL is valid for the SOFAR 1100TL, SOFAR 1600TL, SOFAR 2200TL and SOFAR 2700TL, since it is same as in hardware and just power derated by software.

U/F stage 1



U/F stage 2



O/F

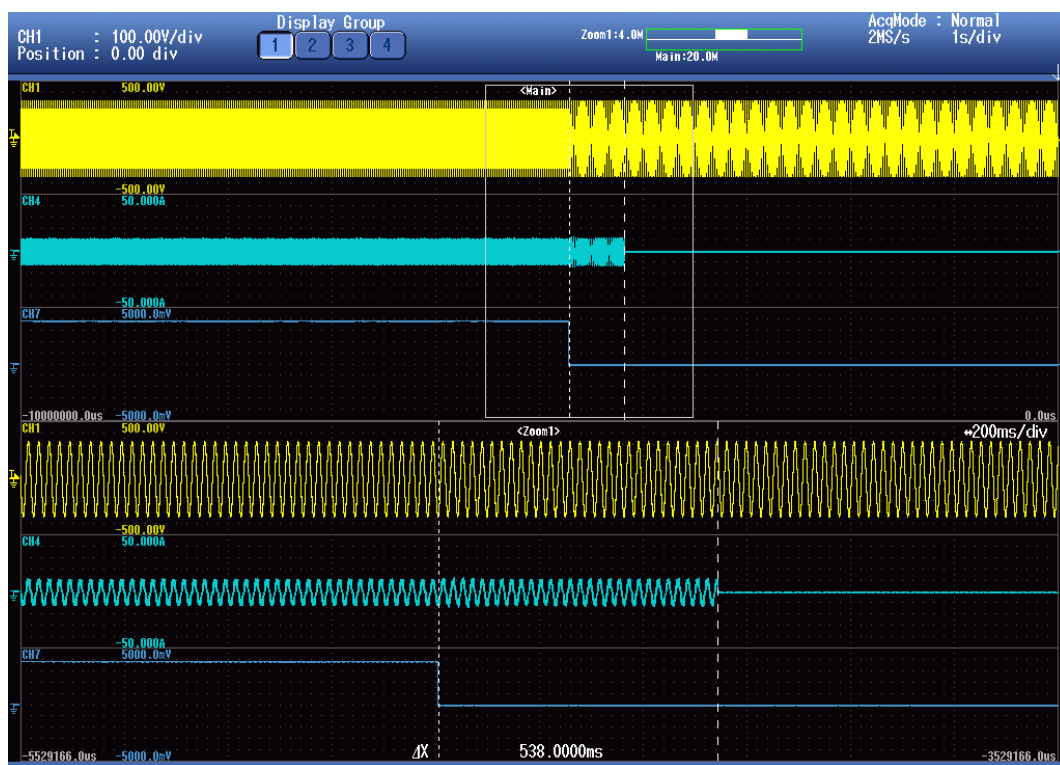

A1.2.4 Loss of mains protection according BS EN 62116									P
The requirement is specified in section 10.2, test procedure in Annex A.2.2.4 Load imbalance (real, reactive load) for test condition A (EUT output = 100%)									
SOFAR 1100TL									
Test conditions		Frequency: 50+/-0,1Hz $U_N=230+/-3V_{ac}$ Distortion factor of chokes < 2% Quality =1							
Disconnection limit		0,5s							
No	$P_{EUT}^{1)}$ (% of EUT rating)	Reactive load (% of Q_L in 6.1.d) 1)	$P_{AC}^{2)}$ (% of nominal)	$Q_{AC}^{3)}$ (% of nominal)	P_{EUT} [W per phase]	V_{DC} [V]	Q_f [1]	Run on Time [ms]	Remarks ⁴⁾
1	100	100	0	0	1019	335	1,02	405	Test A at BL
4	100	100	-5	-5	1019	335	0,94	95	Test A at IB
5	100	100	-5	0	1019	335	0,97	376	Test A at IB
6	100	100	-5	+5	1019	335	0,99	126	Test A at IB
7	100	100	0	-5	1019	335	0,99	72	Test A at IB
8	100	100	0	+5	1019	335	1,04	169	Test A at IB
9	100	100	+5	-5	1019	335	1,04	61	Test A at IB
10	100	100	+5	0	1019	335	1,07	223	Test A at IB
11	100	100	+5	+5	1019	335	1,09	170	Test A at IB
Parameter at 0%			L= 161,13 mH		R= 51,91 Ω		C= 61,62 μF		
Indicate additional shut down time included in above results. (Disconnection device operation time)								20ms	
<p>Note: Note for technologies which have a substantial shut down time this can be added to the 0.5 seconds in establishing that the trip occurred in less than 0.5s. Maximum shut down time could therefore be up to 1.0 seconds for these technologies. RLC is adjusted to min. +/-1% of the inverter rated output power</p> <p>1) P_{EUT}: EUT output power 2) P_{AC}: Real power flow at S1 in Figure 1. Positive means power from EUT to utility. Nominal is the 0 % test condition value. 3) Q_{AC}: Reactive power flow at S1 in Figure 1. Positive means power from EUT to utility. Nominal is the 0 % test condition value. 4) BL: Balance condition, IB: Imbalance condition. Condition A: EUT output power $P_{EUT} = \text{Maximum}^5)$ EUT input voltage $^{6)} = >90\%$ of rated input voltage range 5) Maximum EUT output power condition should be achieved using the maximum allowable input power. Actual output power may exceed nominal rated output. 6) Based on EUT rated input operating range. For example, If range is between X volts and Y volts, 90 % of range = $X + 0,9 \times (Y - X)$. Y shall not exceed $0,8 \times$ EUT maximum system voltage (i.e., maximum allowable array open circuit voltage). In any case, the EUT should not be operated outside of its allowable input voltage range.</p>									

The results refer to the original test report PVUK140508N005 issued by Bureau Veritas Shenzhen Co., Ltd. Dongguan Branch, dated on Jul. 22, 2014.

Disconnection at P_{AC} 0% and Q_{AC} 0% reactive load and 100% nominal power



Note:

C1: EUT Current
C2: Fundamental of I_{AC}

A1.3.4 Loss of mains protection according BS EN 62116									P
The requirement is specified in section 10.2, test procedure in Annex A.2.2.4 Load imbalance (real, reactive load) for test condition A (EUT output = 50 % – 66 %)									
SOFAR 1100TL									
Test conditions		Frequency: 50+/-0,1Hz U _N =230+/-3Vac Distortion factor of chokes < 2% Quality =1							
Disconnection limit		0,5s							
No	P _{EUT} ¹⁾ (% of EUT rating)	Reactive load (% of Q _L in 6.1.d) 1)	P _{AC} ²⁾ (% of nominal)	Q _{AC} ³⁾ (% of nominal)	P _{EUT} [W per phase]	V _{DC} [V]	Q _f [1]	Run on Time [ms]	Remarks ⁴⁾
12	66	66	0	-5	629	235	0,98	88	Test B at IB
13	66	66	0	-4	629	235	0,98	146	Test B at IB
14	66	66	0	-3	629	235	0,99	201	Test B at IB
15	66	66	0	-2	629	235	0,99	196	Test B at IB
16	66	66	0	-1	629	235	1,00	299	Test B at IB
2	66	66	0	0	629	235	1,00	299	Test B at BL
17	66	66	0	1	629	235	1,01	409	Test B at IB
18	66	66	0	2	629	235	1,01	465	Test B at IB
19	66	66	0	3	629	235	1,02	311	Test B at IB
20	66	66	0	4	629	235	1,02	144	Test B at IB
21	66	66	0	5	629	235	1,03	209	Test B at IB
Parameter at 0%			L= 263,10 mH		R= 84,10 Ω		C= 37,55 μF		
Indicate additional shut down time included in above results. (Disconnection device operation time)								20ms	
Note: RLC is adjusted to min. +/-1% of the inverter rated output power 1) P _{EUT} : EUT output power 2) P _{AC} : Real power flow at S1 in Figure 1. Positive means power from EUT to utility. Nominal is the 0 % test condition value. 3) Q _{AC} : Reactive power flow at S1 in Figure 1. Positive means power from EUT to utility. Nominal is the 0 % test condition value. 4) BL: Balance condition, IB: Imbalance condition. Condition B: EUT output power P _{EUT} = 50 % – 66 % of maximum EUT input voltage ⁵⁾ = 50 % of rated input voltage range, ±10 % 5) Based on EUT rated input operating range. For example, If range is between X volts and Y volts, 90 % of range =X + 0,5 × (Y – X). Y shall not exceed 0,8 × EUT maximum system voltage (i.e., maximum allowable array open circuit voltage). In any case, the EUT should not be operated outside of its allowable input voltage range. The results refer to the original test report PVUK140508N005 issued by Bureau Veritas Shenzhen Co., Ltd. Dongguan Branch, dated on Jul. 22, 2014.									

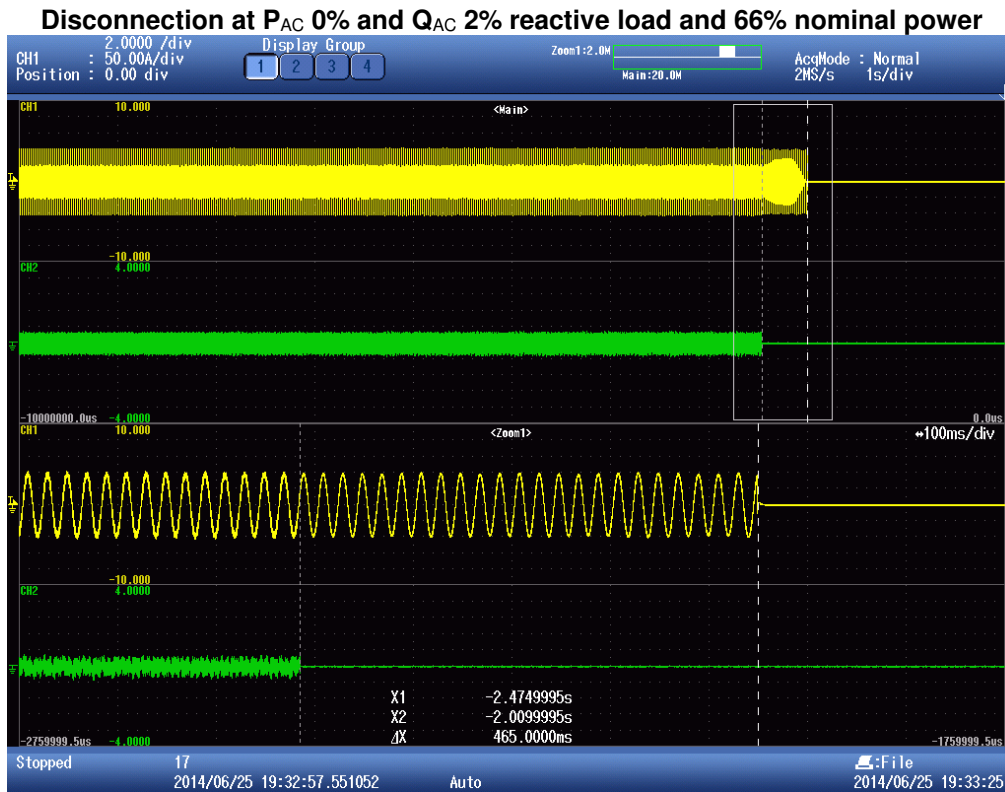

Note:

C1: EUT Current

C2: Fundamental of I_{AC}

A1.3.4 Loss of mains protection according BS EN 62116									P
The requirement is specified in section 10.2, test procedure in Annex A.2.2.4 Load imbalance (real, reactive load) for test condition A (EUT output = 25 % – 33 %)									
SOFAR 1100TL									
Test conditions		Frequency: 50+/-0,1Hz U _N =230+/-3Vac Distortion factor of chokes < 2% Quality =1							
Disconnection limit		0,5s							
No	P _{EUT} ¹⁾ (% of EUT rating)	Reactive load (% of Q _L in 6.1.d) 1)	P _{AC} ²⁾ (% of nominal)	Q _{AC} ³⁾ (% of nominal)	P _{EUT} [W per phase]	V _{DC} [V]	Q _f [1]	Run on Time [ms]	Remarks ⁴⁾
22	33	33	0	-5	303	135	0,99	100	Test B at IB
23	33	33	0	-4	303	135	1,00	45	Test B at IB
24	33	33	0	-3	303	135	1,00	220	Test B at IB
25	33	33	0	-2	303	135	1,01	128	Test B at IB
26	33	33	0	-1	303	135	1,01	236	Test B at IB
3	33	33	0	0	303	135	1,02	475	Test B at BL
27	33	33	0	1	303	135	1,02	359	Test B at IB
28	33	33	0	2	303	135	1,03	243	Test B at IB
29	33	33	0	3	303	135	1,03	146	Test B at IB
30	33	33	0	4	303	135	1,04	204	Test B at IB
31	33	33	0	5	303	135	1,04	131	Test B at IB
Parameter at 0%			L= 536,26 mH		R= 174,59 Ω		C= 18,29 μF		
Indicate additional shut down time included in above results. (Disconnection device operation time)								20ms	
Note: RLC is adjusted to min. +/-1% of the inverter rated output power 1) P _{EUT} : EUT output power 2) P _{AC} : Real power flow at S1 in Figure 1. Positive means power from EUT to utility. Nominal is the 0 % test condition value. 3) Q _{AC} : Reactive power flow at S1 in Figure 1. Positive means power from EUT to utility. Nominal is the 0 % test condition value. 4) BL: Balance condition, IB: Imbalance condition. Condition C: EUT output power P _{EUT} = 25 % – 33 % ⁵⁾ of maximum EUT input voltage ⁶⁾ = <10 % of rated input voltage range 5) Or minimum allowable EUT output level if greater than 33 %. 6) Based on EUT rated input operating range. For example, If range is between X volts and Y volts, 90 % of range =X + 0,1 × (Y – X). Y shall not exceed 0,8 × EUT maximum system voltage (i.e., maximum allowable array open circuit voltage). In any case, the EUT should not be operated outside of its allowable input voltage range.									

The results refer to the original test report PVUK140508N005 issued by Bureau Veritas Shenzhen Co., Ltd. Dongguan Branch, dated on Jul. 22, 2014.

Disconnection at P_{AC} 0% and Q_{AC} 0% reactive load and 33% nominal power



Note:
 C1: EUT Current
 C2: Fundamental of I_{AC}

A1.2.4 Loss of mains protection according BS EN 62116									P
The requirement is specified in section 10.2, test procedure in Annex A.2.2.4 Load imbalance (real, reactive load) for test condition A (EUT output = 100%)									
SOFAR 1600TL									
Test conditions		Frequency: 50+/-0,1Hz $U_N=230+/-3V_{ac}$ Distortion factor of chokes < 2% Quality =1							
Disconnection limit		0,5s							
No	$P_{EUT}^{1)}$ (% of EUT rating)	Reactive load (% of Q_L in 6.1.d) 1)	$P_{AC}^{2)}$ (% of nominal)	$Q_{AC}^{3)}$ (% of nominal)	P_{EUT} [W per phase]	V_{DC} [V]	Q_f [1]	Run on Time [ms]	Remarks ⁴⁾
1	100	100	0	0	1499	340,5	1,02	370	Test A at BL
4	100	100	-5	-5	1499	340,5	0,94	353	Test A at IB
5	100	100	-5	0	1499	340,5	0,97	303	Test A at IB
6	100	100	-5	+5	1499	340,5	0,99	286	Test A at IB
7	100	100	0	-5	1499	340,5	0,99	285	Test A at IB
8	100	100	0	+5	1499	340,5	1,04	348	Test A at IB
9	100	100	+5	-5	1499	340,5	1,04	369	Test A at IB
10	100	100	+5	0	1499	340,5	1,07	301	Test A at IB
11	100	100	+5	+5	1499	340,5	1,10	347	Test A at IB
Parameter at 0%			L= 108,71 mH		R= 35,29 Ω		C= 90,26 μF		
Indicate additional shut down time included in above results. (Disconnection device operation time)								20ms	
<p>Note: Note for technologies which have a substantial shut down time this can be added to the 0.5 seconds in establishing that the trip occurred in less than 0.5s. Maximum shut down time could therefore be up to 1.0 seconds for these technologies. RLC is adjusted to min. +/-1% of the inverter rated output power</p> <p>1) P_{EUT}: EUT output power 2) P_{AC}: Real power flow at S1 in Figure 1. Positive means power from EUT to utility. Nominal is the 0 % test condition value. 3) Q_{AC}: Reactive power flow at S1 in Figure 1. Positive means power from EUT to utility. Nominal is the 0 % test condition value. 4) BL: Balance condition, IB: Imbalance condition. Condition A: EUT output power $P_{EUT} = \text{Maximum}^{5)}$ EUT input voltage $^{6)} = >90\%$ of rated input voltage range 5) Maximum EUT output power condition should be achieved using the maximum allowable input power. Actual output power may exceed nominal rated output. 6) Based on EUT rated input operating range. For example, If range is between X volts and Y volts, 90 % of range = $X + 0,9 \times (Y - X)$. Y shall not exceed $0,8 \times$ EUT maximum system voltage (i.e., maximum allowable array open circuit voltage). In any case, the EUT should not be operated outside of its allowable input voltage range.</p>									

The results refer to the original test report PVUK140508N005 issued by Bureau Veritas Shenzhen Co., Ltd. Dongguan Branch, dated on Jul. 22, 2014.

Disconnection at P_{AC} 0% and Q_{AC} 0% reactive load and 100% nominal power

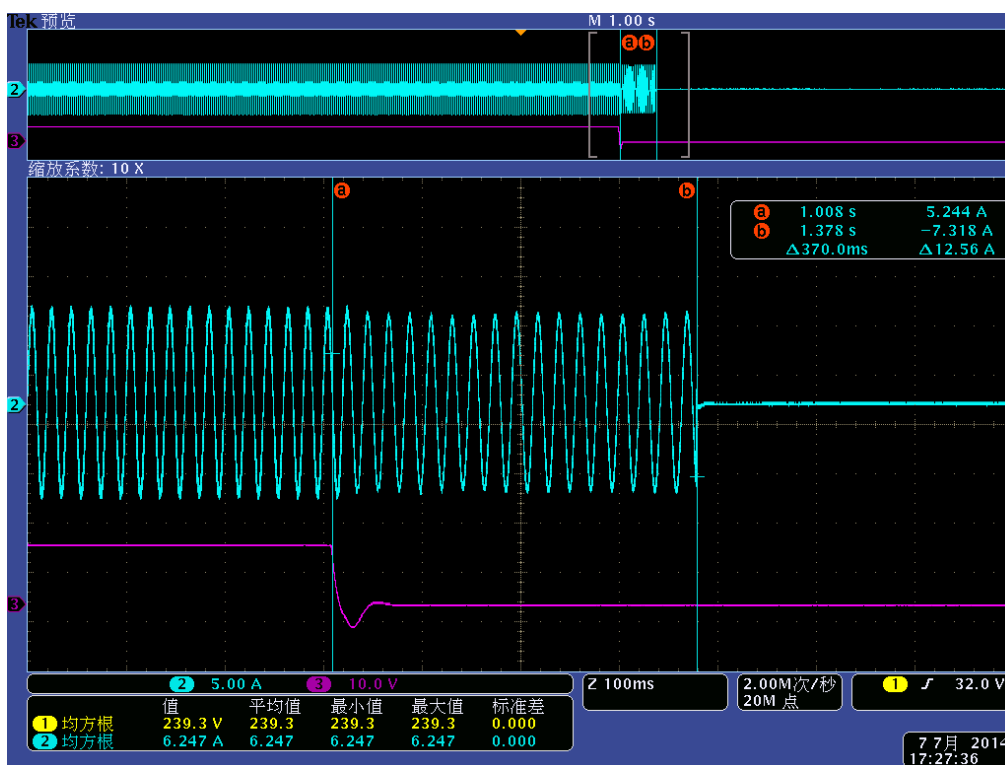

Note:

C1: EUT Current
C2: Fundamental of I_{AC}

A1.3.4 Loss of mains protection according BS EN 62116									P
The requirement is specified in section 10.2, test procedure in Annex A.2.2.4 Load imbalance (real, reactive load) for test condition A (EUT output = 50 % – 66 %)									
SOFAR 1600TL									
Test conditions		Frequency: 50+/-0,1Hz U _N =230+/-3Vac Distortion factor of chokes < 2% Quality =1							
Disconnection limit		0,5s							
No	P _{EUT} ¹⁾ (% of EUT rating)	Reactive load (% of Q _L in 6.1.d) 1)	P _{AC} ²⁾ (% of nominal)	Q _{AC} ³⁾ (% of nominal)	P _{EUT} [W per phase]	V _{DC} [V]	Q _f [1]	Run on Time [ms]	Remarks ⁴⁾
12	66	66	0	-5	912	262,5	1,00	356	Test B at IB
13	66	66	0	-4	912	262,5	1,00	347	Test B at IB
14	66	66	0	-3	912	262,5	1,01	407	Test B at IB
15	66	66	0	-2	912	262,5	1,01	443	Test B at IB
16	66	66	0	-1	912	262,5	1,02	333	Test B at IB
2	66	66	0	0	912	262,5	1,02	379	Test B at BL
17	66	66	0	1	912	262,5	1,03	426	Test B at IB
18	66	66	0	2	912	262,5	1,03	389	Test B at IB
19	66	66	0	3	912	262,5	1,04	330	Test B at IB
20	66	66	0	4	912	262,5	1,04	448	Test B at IB
21	66	66	0	5	912	262,5	1,05	303	Test B at IB
Parameter at 0%		L= 177,44 mH		R= 58,00 Ω		C= 55,24 μF			
Indicate additional shut down time included in above results. (Disconnection device operation time)								20ms	
Note: RLC is adjusted to min. +/-1% of the inverter rated output power 1) P _{EUT} : EUT output power 2) P _{AC} : Real power flow at S1 in Figure 1. Positive means power from EUT to utility. Nominal is the 0 % test condition value. 3) Q _{AC} : Reactive power flow at S1 in Figure 1. Positive means power from EUT to utility. Nominal is the 0 % test condition value. 4) BL: Balance condition, IB: Imbalance condition. Condition B: EUT output power P _{EUT} = 50 % – 66 % of maximum EUT input voltage ⁵⁾ = 50 % of rated input voltage range, ±10 % 5) Based on EUT rated input operating range. For example, If range is between X volts and Y volts, 90 % of range = X + 0,5 × (Y – X). Y shall not exceed 0,8 × EUT maximum system voltage (i.e., maximum allowable array open circuit voltage). In any case, the EUT should not be operated outside of its allowable input voltage range. The results refer to the original test report PVUK140508N005 issued by Bureau Veritas Shenzhen Co., Ltd. Dongguan Branch, dated on Jul. 22, 2014.									

Disconnection at P_{AC} 0% and Q_{AC} 4% reactive load and 66% nominal power

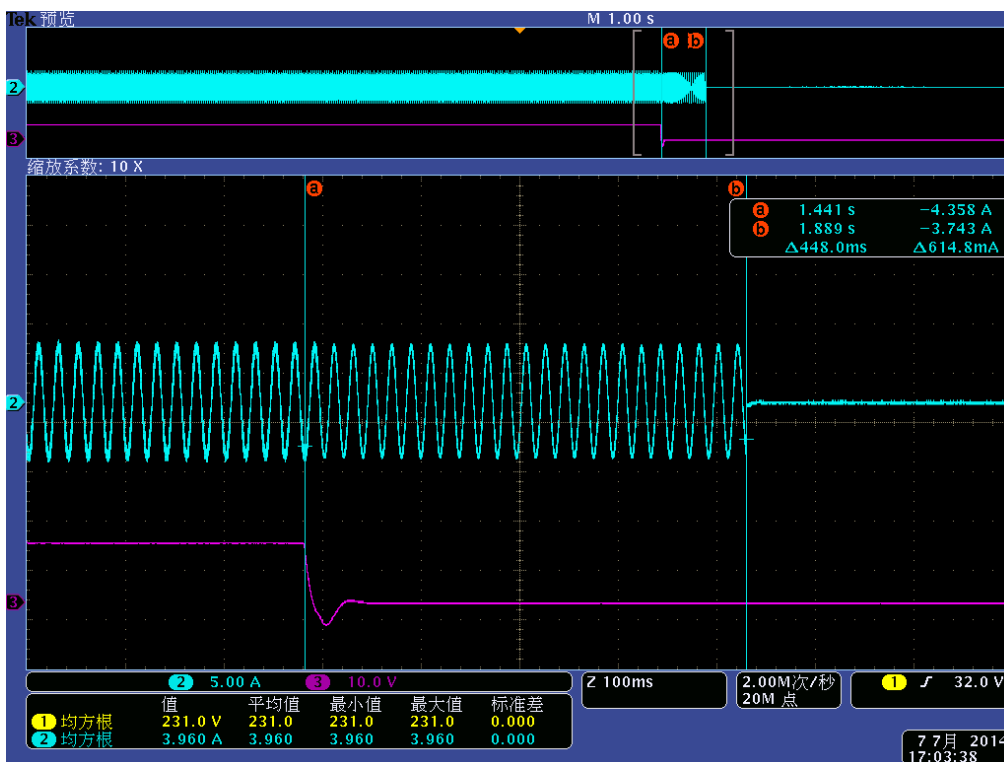

Note:

C1: EUT Current

C2: Fundamental of I_{AC}

A1.3.4 Loss of mains protection according BS EN 62116									P
The requirement is specified in section 10.2, test procedure in Annex A.2.2.4 Load imbalance (real, reactive load) for test condition A (EUT output = 25 % – 33 %)									
SOFAR 1600TL									
Test conditions		Frequency: 50+/-0,1Hz U _N =230+/-3Vac Distortion factor of chokes < 2% Quality =1							
Disconnection limit		0,5s							
No	P _{EUT} ¹⁾ (% of EUT rating)	Reactive load (% of Q _L in 6.1.d) 1)	P _{AC} ²⁾ (% of nominal)	Q _{AC} ³⁾ (% of nominal)	P _{EUT} [W per phase]	V _{DC} [V]	Q _f [1]	Run on Time [ms]	Remarks ⁴⁾
22	33	33	0	-5	439	184,5	0,99	100	Test B at IB
23	33	33	0	-4	439	184,5	1,00	45	Test B at IB
24	33	33	0	-3	439	184,5	1,00	220	Test B at IB
25	33	33	0	-2	439	184,5	1,01	128	Test B at IB
26	33	33	0	-1	439	184,5	1,01	236	Test B at IB
3	33	33	0	0	439	184,5	1,02	475	Test B at BL
27	33	33	0	1	439	184,5	1,02	359	Test B at IB
28	33	33	0	2	439	184,5	1,03	243	Test B at IB
29	33	33	0	3	439	184,5	1,03	146	Test B at IB
30	33	33	0	4	439	184,5	1,04	204	Test B at IB
31	33	33	0	5	439	184,5	1,04	131	Test B at IB
Parameter at 0%			L= 370,08 mH		R= 120,50 Ω		C= 26,36 μF		
Indicate additional shut down time included in above results. (Disconnection device operation time)								20ms	
Note:									
RLC is adjusted to min. +/-1% of the inverter rated output power									
1) P _{EUT} : EUT output power									
2) P _{AC} : Real power flow at S1 in Figure 1. Positive means power from EUT to utility. Nominal is the 0 % test condition value.									
3) Q _{AC} : Reactive power flow at S1 in Figure 1. Positive means power from EUT to utility. Nominal is the 0 % test condition value.									
4) BL: Balance condition, IB: Imbalance condition.									
Condition C:									
EUT output power P _{EUT} = 25 % – 33 % ⁵⁾ of maximum									
EUT input voltage ⁶⁾ = <10 % of rated input voltage range									
5) Or minimum allowable EUT output level if greater than 33 %.									
6) Based on EUT rated input operating range. For example, If range is between X volts and Y volts, 90 % of range =X + 0,1 × (Y – X). Y shall not exceed 0,8 × EUT maximum system voltage (i.e., maximum allowable array open circuit voltage). In any case, the EUT should not be operated outside of its allowable input voltage range.									

The results refer to the original test report PVUK140508N005 issued by Bureau Veritas Shenzhen Co., Ltd. Dongguan Branch, dated on Jul. 22, 2014.

Disconnection at P_{AC} 0%? and Q_{AC} -3% reactive load and 33% nominal power

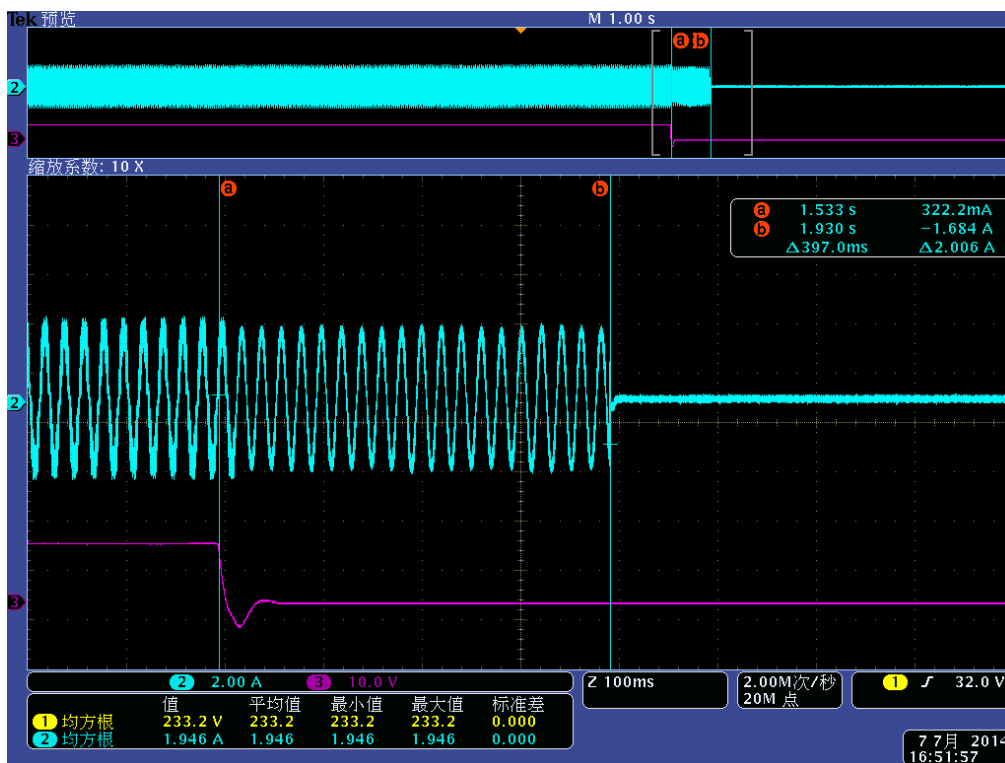

Note:

C1: EUT Current

C2: Fundamental of I_{AC}

A1.2.4 Loss of mains protection according BS EN 62116									P
The requirement is specified in section 10.2, test procedure in Annex A.2.2.4 Load imbalance (real, reactive load) for test condition A (EUT output = 100%)									
SOFAR 2200TL									
Test conditions		Frequency: 50+/-0,1Hz $U_N=230\pm 3V_{ac}$ Distortion factor of chokes < 2% Quality =1							
Disconnection limit		0,5s							
No	$P_{EUT}^{1)}$ (% of EUT rating)	Reactive load (% of QL in 6.1.d) 1)	$P_{AC}^{2)}$ (% of nominal)	$Q_{AC}^{3)}$ (% of nominal)	P_{EUT} [W per phase]	V_{DC} [V]	Q_f [1]	Run on Time [ms]	Remarks ⁴⁾
1	100	100	0	0	2032	377	1,01	441	Test A at BL
4	100	100	-5	-5	2032	377	0,94	100	Test A at IB
5	100	100	-5	0	2032	377	0,97	433	Test A at IB
6	100	100	-5	+5	2032	377	0,99	164	Test A at IB
7	100	100	0	-5	2032	377	0,99	138	Test A at IB
8	100	100	0	+5	2032	377	1,04	123	Test A at IB
9	100	100	+5	-5	2032	377	1,04	105	Test A at IB
10	100	100	+5	0	2032	377	1,07	408	Test A at IB
11	100	100	+5	+5	2032	377	1,09	121	Test A at IB
Parameter at 0%		L= 80,76 mH		R= 26,03 Ω		C= 122,51 μF			
Indicate additional shut down time included in above results. (Disconnection device operation time)								20ms	
<p>Note: Note for technologies which have a substantial shut down time this can be added to the 0.5 seconds in establishing that the trip occurred in less than 0.5s. Maximum shut down time could therefore be up to 1.0 seconds for these technologies. RLC is adjusted to min. +/-1% of the inverter rated output power</p> <p>1) P_{EUT}: EUT output power 2) P_{AC}: Real power flow at S1 in Figure 1. Positive means power from EUT to utility. Nominal is the 0 % test condition value. 3) Q_{AC}: Reactive power flow at S1 in Figure 1. Positive means power from EUT to utility. Nominal is the 0 % test condition value. 4) BL: Balance condition, IB: Imbalance condition. Condition A: EUT output power $P_{EUT} = \text{Maximum}^{5)}$ EUT input voltage $^{6)} = >90\%$ of rated input voltage range 5) Maximum EUT output power condition should be achieved using the maximum allowable input power. Actual output power may exceed nominal rated output. 6) Based on EUT rated input operating range. For example, If range is between X volts and Y volts, 90 % of range = $X + 0,9 \times (Y - X)$. Y shall not exceed $0,8 \times$ EUT maximum system voltage (i.e., maximum allowable array open circuit voltage). In any case, the EUT should not be operated outside of its allowable input voltage range.</p>									

The results refer to the original test report PVUK140508N005 issued by Bureau Veritas Shenzhen Co., Ltd. Dongguan Branch, dated on Jul. 22, 2014.

Disconnection at P_{AC} 0% and Q_{AC} 0% reactive load and 100% nominal power

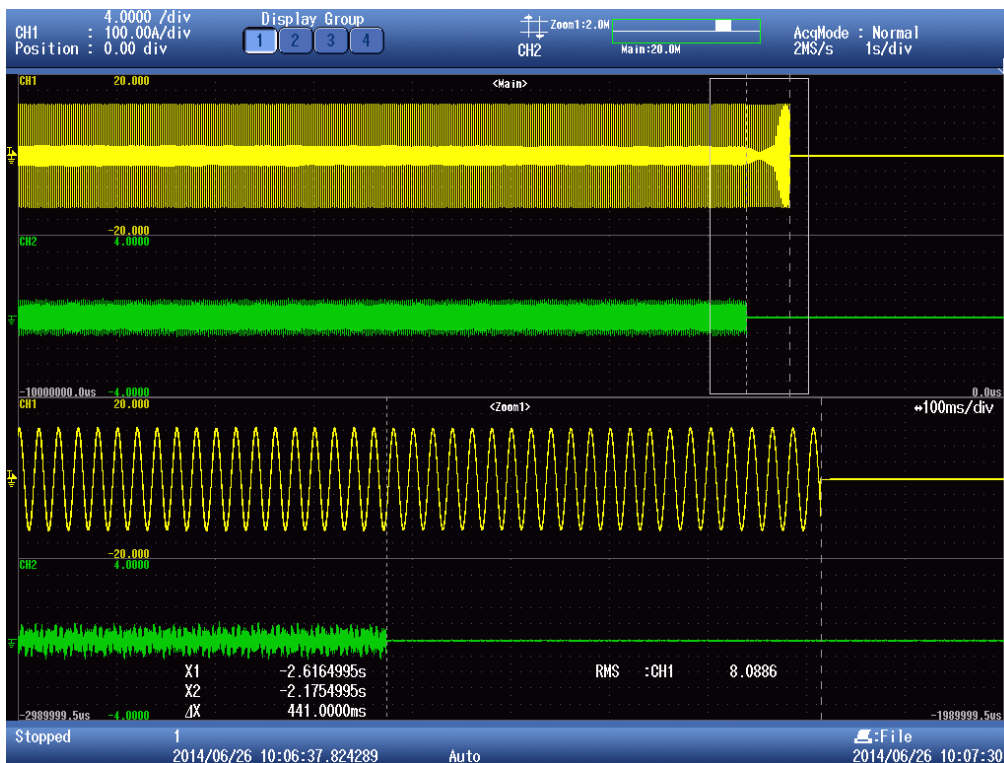

Note:

C1: EUT Current
C2: Fundamental of I_{AC}

A1.3.4 Loss of mains protection according BS EN 62116									P
The requirement is specified in section 10.2, test procedure in Annex A.2.2.4 Load imbalance (real, reactive load) for test condition A (EUT output = 50 % – 66 %)									
SOFAR 2200TL									
Test conditions		Frequency: 50+/-0,1Hz U _N =230+/-3Vac Distortion factor of chokes < 2% Quality =1							
Disconnection limit		0,5s							
No	P _{EUT} ¹⁾ (% of EUT rating)	Reactive load (% of Q _L in 6.1.d) 1)	P _{AC} ²⁾ (% of nominal)	Q _{AC} ³⁾ (% of nominal)	P _{EUT} [W per phase]	V _{DC} [V]	Q _f [1]	Run on Time [ms]	Remarks ⁴⁾
12	66	66	0	-5	1240	285	0,98	95	Test B at IB
13	66	66	0	-4	1240	285	0,99	108	Test B at IB
14	66	66	0	-3	1240	285	0,99	212	Test B at IB
15	66	66	0	-2	1240	285	1,00	239	Test B at IB
16	66	66	0	-1	1240	285	1,00	308	Test B at IB
2	66	66	0	0	1240	285	1,01	292	Test B at BL
17	66	66	0	1	1240	285	1,01	419	Test B at IB
18	66	66	0	2	1240	285	1,02	307	Test B at IB
19	66	66	0	3	1240	285	1,02	200	Test B at IB
20	66	66	0	4	1240	285	1,03	217	Test B at IB
21	66	66	0	5	1240	285	1,03	128	Test B at IB
Parameter at 0%		L= 133,53 mH		R= 42,66 Ω		C= 74,43 μF			
Indicate additional shut down time included in above results. (Disconnection device operation time)								20ms	
Note: RLC is adjusted to min. +/-1% of the inverter rated output power 1) P _{EUT} : EUT output power 2) P _{AC} : Real power flow at S1 in Figure 1. Positive means power from EUT to utility. Nominal is the 0 % test condition value. 3) Q _{AC} : Reactive power flow at S1 in Figure 1. Positive means power from EUT to utility. Nominal is the 0 % test condition value. 4) BL: Balance condition, IB: Imbalance condition. Condition B: EUT output power P _{EUT} = 50 % – 66 % of maximum EUT input voltage ⁵⁾ = 50 % of rated input voltage range, ±10 % 5) Based on EUT rated input operating range. For example, If range is between X volts and Y volts, 90 % of range = X + 0,5 × (Y – X). Y shall not exceed 0,8 × EUT maximum system voltage (i.e., maximum allowable array open circuit voltage). In any case, the EUT should not be operated outside of its allowable input voltage range. The results refer to the original test report PVUK140508N005 issued by Bureau Veritas Shenzhen Co., Ltd. Dongguan Branch, dated on Jul. 22, 2014.									

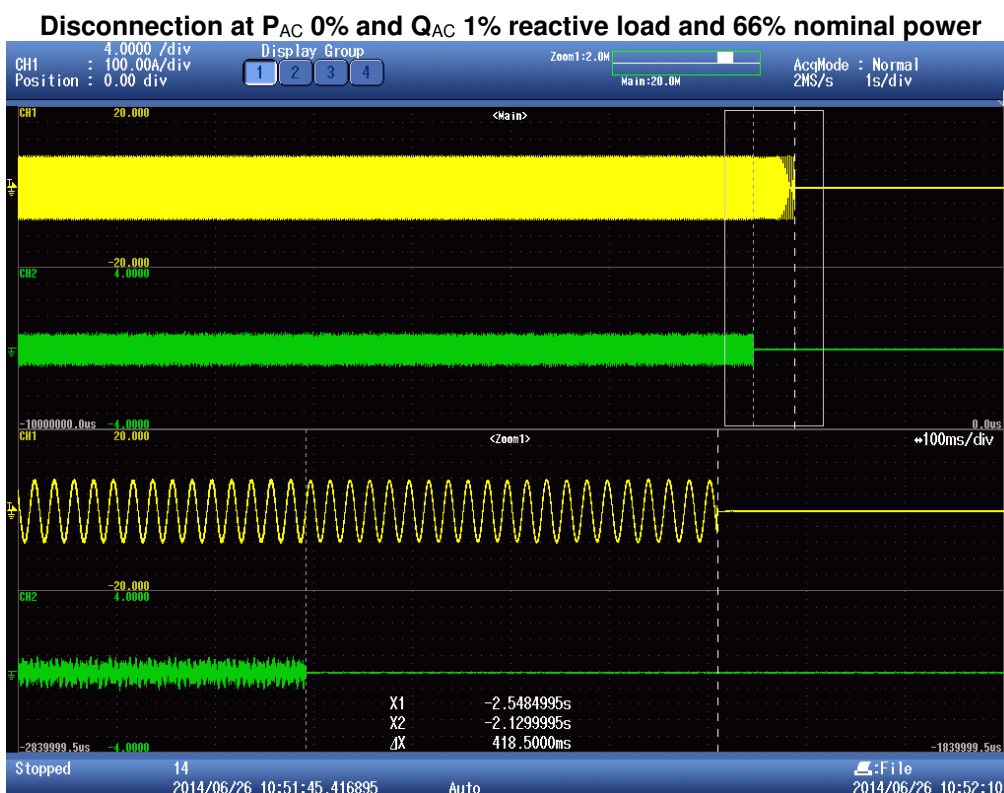

Note:

C1: EUT Current
C2: Fundamental of I_{AC}

A1.3.4 Loss of mains protection according BS EN 62116									P
The requirement is specified in section 10.2, test procedure in Annex A.2.2.4 Load imbalance (real, reactive load) for test condition A (EUT output = 25 % – 33 %)									
SOFAR 2200TL									
Test conditions		Frequency: 50+/-0,1Hz U _N =230+/-3Vac Distortion factor of chokes < 2% Quality =1							
Disconnection limit		0,5s							
No	P _{EUT} ¹⁾ (% of EUT rating)	Reactive load (% of Q _L in 6.1.d) 1)	P _{AC} ²⁾ (% of nominal)	Q _{AC} ³⁾ (% of nominal)	P _{EUT} [W per phase]	V _{DC} [V]	Q _f [1]	Run on Time [ms]	Remarks ⁴⁾
32	33	33	0	-6	594	193	0,99	153	Test B at IB
22	33	33	0	-5	594	193	0,99	172	Test B at IB
23	33	33	0	-4	594	193	1,00	140	Test B at IB
24	33	33	0	-3	594	193	1,00	124	Test B at IB
25	33	33	0	-2	594	193	1,01	211	Test B at IB
26	33	33	0	-1	594	193	1,01	140	Test B at BL
3	33	33	0	0	594	193	1,02	197	Test B at IB
27	33	33	0	1	594	193	1,02	470	Test B at IB
28	33	33	0	2	594	193	1,03	366	Test B at IB
29	33	33	0	3	594	193	1,03	255	Test B at IB
30	33	33	0	4	594	193	1,04	180	Test B at IB
31	33	33	0	5	594	193	1,04	65	Test B at IB
Parameter at 0%			L= 275,59 mH		R= 89,06 Ω		C= 35,92 μF		
Indicate additional shut down time included in above results. (Disconnection device operation time)								20ms	
<p>Note: RLC is adjusted to min. +/-1% of the inverter rated output power 1) P_{EUT}: EUT output power 2) P_{AC}: Real power flow at S1 in Figure 1. Positive means power from EUT to utility. Nominal is the 0 % test condition value. 3) Q_{AC}: Reactive power flow at S1 in Figure 1. Positive means power from EUT to utility. Nominal is the 0 % test condition value. 4) BL: Balance condition, IB: Imbalance condition. Condition C: EUT output power P_{EUT} = 25 % – 33 %⁵⁾ of maximum EUT input voltage⁶⁾ = <10 % of rated input voltage range 5) Or minimum allowable EUT output level if greater than 33 %. 6) Based on EUT rated input operating range. For example, If range is between X volts and Y volts, 90 % of range = X + 0,1 × (Y – X). Y shall not exceed 0,8 × EUT maximum system voltage (i.e., maximum allowable array open circuit voltage). In any case, the EUT should not be operated outside of its allowable input voltage range.</p>									

The results refer to the original test report PVUK140508N005 issued by Bureau Veritas Shenzhen Co., Ltd. Dongguan Branch, dated on Jul. 22, 2014.

Disconnection at P_{AC} 0% and Q_{AC} 1% reactive load and 33% nominal power



Note:

C1: EUT Current
 C2: Fundamental of I_{AC}

A1.2.4 Loss of mains protection according BS EN 62116									P
The requirement is specified in section 10.2, test procedure in Annex A.2.2.4 Load imbalance (real, reactive load) for test condition A (EUT output = 100%)									
SOFAR 2700TL									
Test conditions		Frequency: 50+/-0,1Hz $U_N=230+/-3V_{ac}$ Distortion factor of chokes < 2% Quality =1							
Disconnection limit		0,5s							
No	$P_{EUT}^{1)}$ (% of EUT rating)	Reactive load (% of Q_L in 6.1.d) 1)	$P_{AC}^{2)}$ (% of nominal)	$Q_{AC}^{3)}$ (% of nominal)	P_{EUT} [W per phase]	V_{DC} [V]	Q_f [1]	Run on Time [ms]	Remarks ⁴⁾
1	100	100	0	0	2496	381	1,01	431	Test A at BL
4	100	100	-5	-5	2496	381	0,94	240	Test A at IB
5	100	100	-5	0	2496	381	0,96	326	Test A at IB
6	100	100	-5	+5	2496	381	9,98	268	Test A at IB
7	100	100	0	-5	2496	381	0,98	237	Test A at IB
8	100	100	0	+5	2496	381	1,03	288	Test A at IB
9	100	100	+5	-5	2496	381	1,03	279	Test A at IB
10	100	100	+5	0	2496	381	1,06	258	Test A at IB
11	100	100	+5	+5	2496	381	1,09	397	Test A at IB
Parameter at 0%		L= 66,22 mH		R= 21,19 Ω		C= 149,59 μF			
Indicate additional shut down time included in above results. (Disconnection device operation time)								20ms	
<p>Note: Note for technologies which have a substantial shut down time this can be added to the 0.5 seconds in establishing that the trip occurred in less than 0.5s. Maximum shut down time could therefore be up to 1.0 seconds for these technologies. RLC is adjusted to min. +/-1% of the inverter rated output power</p> <p>1) P_{EUT}: EUT output power 2) P_{AC}: Real power flow at S1 in Figure 1. Positive means power from EUT to utility. Nominal is the 0 % test condition value. 3) Q_{AC}: Reactive power flow at S1 in Figure 1. Positive means power from EUT to utility. Nominal is the 0 % test condition value. 4) BL: Balance condition, IB: Imbalance condition. Condition A: EUT output power $P_{EUT} = \text{Maximum}^5)$ EUT input voltage $^{6)} = >90\%$ of rated input voltage range 5) Maximum EUT output power condition should be achieved using the maximum allowable input power. Actual output power may exceed nominal rated output. 6) Based on EUT rated input operating range. For example, If range is between X volts and Y volts, 90 % of range = $X + 0,9 \times (Y - X)$. Y shall not exceed $0,8 \times$ EUT maximum system voltage (i.e., maximum allowable array open circuit voltage). In any case, the EUT should not be operated outside of its allowable input voltage range.</p>									

The results refer to the original test report PVUK140508N005 issued by Bureau Veritas Shenzhen Co., Ltd. Dongguan Branch, dated on Jul. 22, 2014.

Disconnection at P_{AC} 0% and Q_{AC} 0% reactive load and 100% nominal power

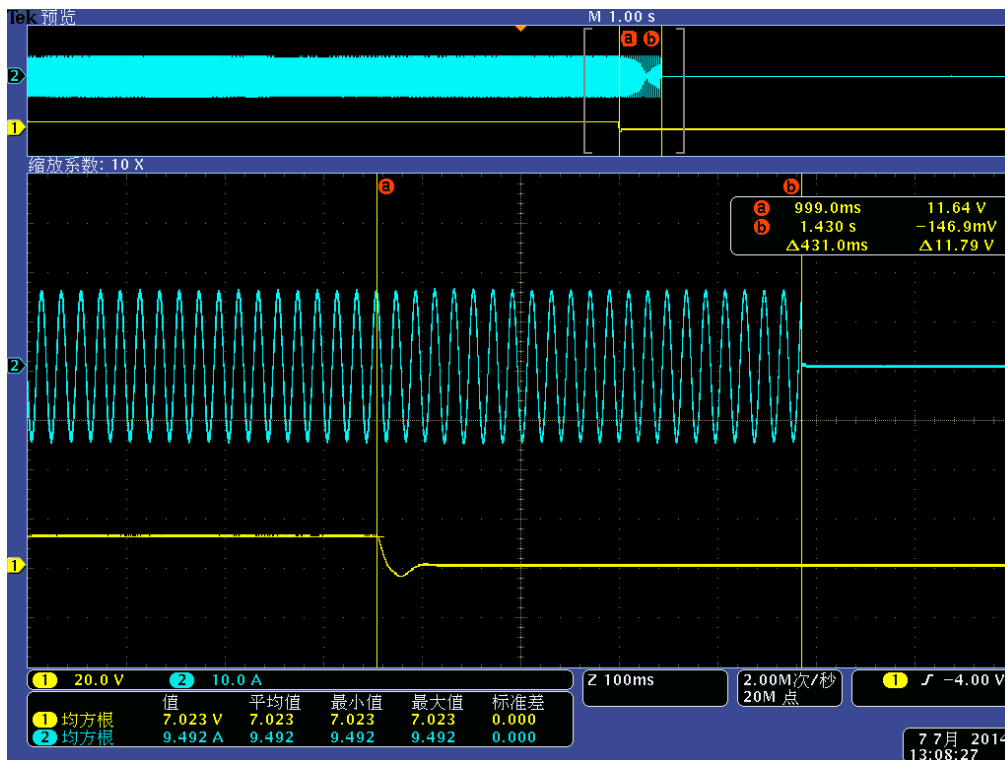

Note:

C1: EUT Current
C2: Fundamental of I_{AC}

A1.3.4 Loss of mains protection according BS EN 62116									P
The requirement is specified in section 10.2, test procedure in Annex A.2.2.4 Load imbalance (real, reactive load) for test condition A (EUT output = 50 % – 66 %)									
SOFAR 2700TL									
Test conditions		Frequency: 50+/-0,1Hz U _N =230+/-3Vac Distortion factor of chokes < 2% Quality =1							
Disconnection limit		0,5s							
No	P _{EUT} ¹⁾ (% of EUT rating)	Reactive load (% of Q _L in 6.1.d) 1)	P _{AC} ²⁾ (% of nominal)	Q _{AC} ³⁾ (% of nominal)	P _{EUT} [W per phase]	V _{DC} [V]	Q _f [1]	Run on Time [ms]	Remarks ⁴⁾
12	66	66	0	-5	1375	305	0,97	239	Test B at IB
13	66	66	0	-4	1375	305	0,98	248	Test B at IB
14	66	66	0	-3	1375	305	0,98	201	Test B at IB
15	66	66	0	-2	1375	305	0,99	237	Test B at IB
16	66	66	0	-1	1375	305	0,99	331	Test B at IB
2	66	66	0	0	1375	305	1,00	390	Test B at BL
17	66	66	0	1	1375	305	1,00	293	Test B at IB
18	66	66	0	2	1375	305	1,01	248	Test B at IB
19	66	66	0	3	1375	305	1,01	222	Test B at IB
20	66	66	0	4	1375	305	1,02	355	Test B at IB
21	66	66	0	5	1375	305	1,02	300	Test B at IB
Parameter at 0%			L= 121,32 mH		R= 38,47 Ω		C= 81,41 μF		
Indicate additional shut down time included in above results. (Disconnection device operation time)								20ms	
Note: RLC is adjusted to min. +/-1% of the inverter rated output power 1) P _{EUT} : EUT output power 2) P _{AC} : Real power flow at S1 in Figure 1. Positive means power from EUT to utility. Nominal is the 0 % test condition value. 3) Q _{AC} : Reactive power flow at S1 in Figure 1. Positive means power from EUT to utility. Nominal is the 0 % test condition value. 4) BL: Balance condition, IB: Imbalance condition. Condition B: EUT output power P _{EUT} = 50 % – 66 % of maximum EUT input voltage ⁵⁾ = 50 % of rated input voltage range, ±10 % 5) Based on EUT rated input operating range. For example, If range is between X volts and Y volts, 90 % of range = X + 0,5 × (Y – X). Y shall not exceed 0,8 × EUT maximum system voltage (i.e., maximum allowable array open circuit voltage). In any case, the EUT should not be operated outside of its allowable input voltage range. The results refer to the original test report PVUK140508N005 issued by Bureau Veritas Shenzhen Co., Ltd. Dongguan Branch, dated on Jul. 22, 2014.									

Disconnection at P_{AC} 0% and Q_{AC} 0% reactive load and 66% nominal power

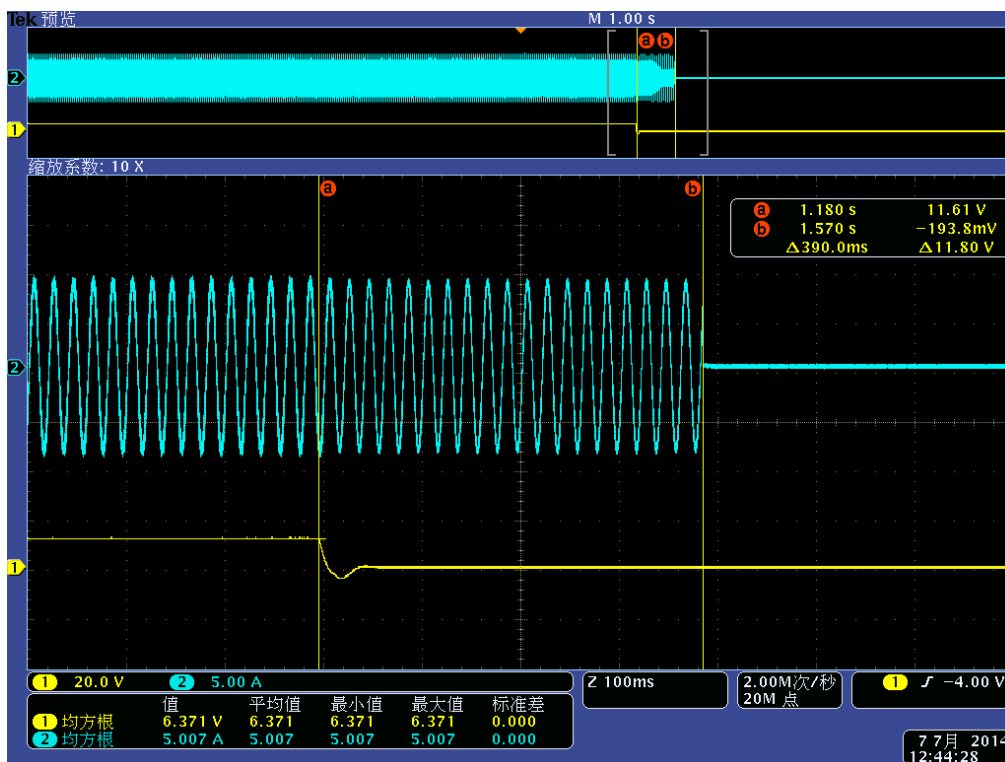

Note:

C1: EUT Current

C2: Fundamental of I_{AC}

A1.3.4 Loss of mains protection according BS EN 62116									P
The requirement is specified in section 10.2, test procedure in Annex A.2.2.4 Load imbalance (real, reactive load) for test condition A (EUT output = 25 % – 33 %)									
SOFAR 2700TL									
Test conditions			Frequency: 50+/-0,1Hz U _N =230+/-3Vac Distortion factor of chokes < 2% Quality =1						
Disconnection limit			0,5s						
No	P _{EUT} ¹⁾ (% of EUT rating)	Reactive load (% of Q _L in 6.1.d) 1)	P _{AC} ²⁾ (% of nominal)	Q _{AC} ³⁾ (% of nominal)	P _{EUT} [W per phase]	V _{DC} [V]	Q _f [1]	Run on Time [ms]	Remarks ⁴⁾
22	33	33	0	-5	745	229	1,01	243	Test B at IB
23	33	33	0	-4	745	229	1,01	264	Test B at IB
24	33	33	0	-3	745	229	1,02	268	Test B at IB
25	33	33	0	-2	745	229	1,02	197	Test B at IB
26	33	33	0	-1	745	229	1,03	176	Test B at IB
3	33	33	0	0	745	229	1,03	296	Test B at BL
27	33	33	0	1	745	229	1,04	219	Test B at IB
28	33	33	0	2	745	229	1,05	231	Test B at IB
29	33	33	0	3	745	229	1,05	342	Test B at IB
30	33	33	0	4	745	229	1,06	351	Test B at IB
31	33	33	0	5	745	229	1,06	287	Test B at IB
Parameter at 0%			L= 219,82 mH		R= 71,01 Ω		C= 46,69 μF		
Indicate additional shut down time included in above results. (Disconnection device operation time)								20ms	
<p>Note: RLC is adjusted to min. +/-1% of the inverter rated output power 1) P_{EUT}: EUT output power 2) P_{AC}: Real power flow at S1 in Figure 1. Positive means power from EUT to utility. Nominal is the 0 % test condition value. 3) Q_{AC}: Reactive power flow at S1 in Figure 1. Positive means power from EUT to utility. Nominal is the 0 % test condition value. 4) BL: Balance condition, IB: Imbalance condition. Condition C: EUT output power P_{EUT} = 25 % – 33 %⁵⁾ of maximum EUT input voltage⁶⁾ = <10 % of rated input voltage range 5) Or minimum allowable EUT output level if greater than 33 %. 6) Based on EUT rated input operating range. For example, If range is between X volts and Y volts, 90 % of range =X + 0,1 × (Y – X). Y shall not exceed 0,8 × EUT maximum system voltage (i.e., maximum allowable array open circuit voltage). In any case, the EUT should not be operated outside of its allowable input voltage range.</p>									

The results refer to the original test report PVUK140508N005 issued by Bureau Veritas Shenzhen Co., Ltd. Dongguan Branch, dated on Jul. 22, 2014.

Disconnection at P_{AC} 0 % and Q_{AC} 4% reactive load and 33% nominal power

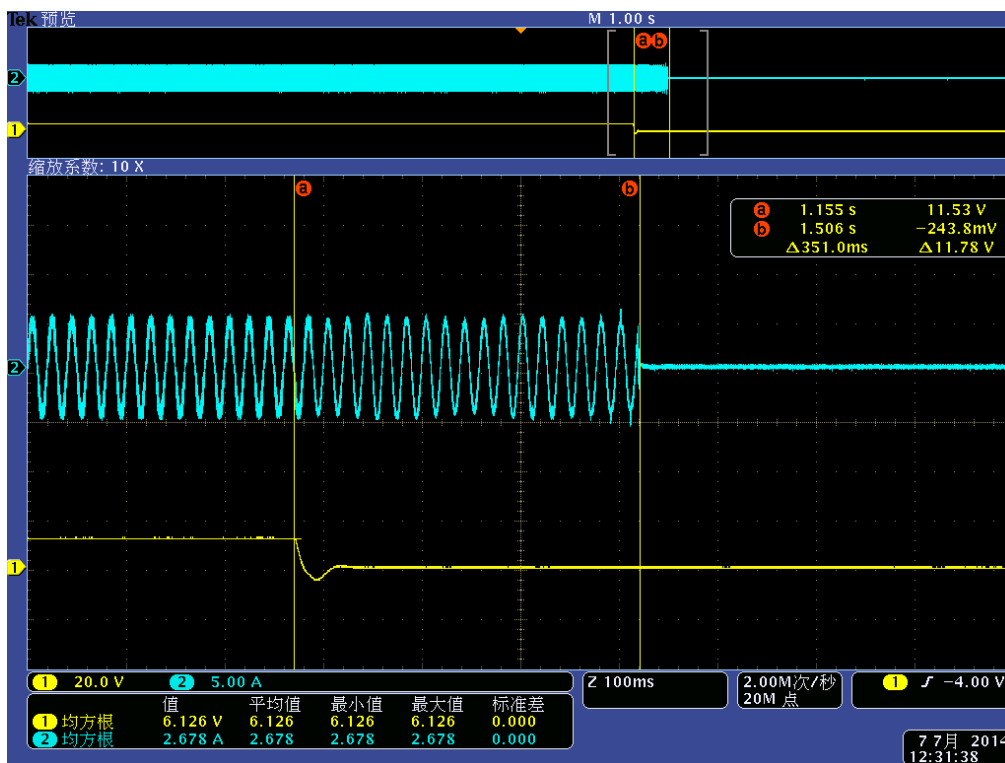

Note:
C1: EUT Current
C2: Fundamental of I_{AC}

A1.2.4 Loss of mains protection according BS EN 62116									P
The requirement is specified in section 10.2, test procedure in Annex A.2.2.4 Load imbalance (real, reactive load) for test condition A (EUT output = 100%)									
SOFAR 3000TL									
Test conditions		Frequency: 50+/-0,1Hz $U_N=230\pm 3V_{ac}$ Distortion factor of chokes < 2% Quality =1							
Disconnection limit		0,5s							
No	$P_{EUT}^{1)}$ (% of EUT rating)	Reactive load (% of Q_L in 6.1.d) 1)	$P_{AC}^{2)}$ (% of nominal)	$Q_{AC}^{3)}$ (% of nominal)	P_{EUT} [W per phase]	V_{DC} [V]	Q_f [1]	Run on Time [ms]	Remarks ⁴⁾
1	100	100	0	0	2821	383	1,00	486	Test A at BL
4	100	100	-5	-5	2821	383	0,93	150	Test A at IB
5	100	100	-5	0	2821	383	0,95	404	Test A at IB
6	100	100	-5	+5	2821	383	0,97	86	Test A at IB
7	100	100	0	-5	2821	383	0,97	195	Test A at IB
8	100	100	0	+5	2821	383	1,02	64	Test A at IB
9	100	100	+5	-5	2821	383	1,02	54	Test A at IB
10	100	100	+5	0	2821	383	1,05	234	Test A at IB
11	100	100	+5	+5	2821	383	1,08	122	Test A at IB
Parameter at 0%		L= 59,84 mH		R= 18,75 Ω		C= 169,75 μF			
Indicate additional shut down time included in above results. (Disconnection device operation time)								20ms	
<p>Note: Note for technologies which have a substantial shut down time this can be added to the 0.5 seconds in establishing that the trip occurred in less than 0.5s. Maximum shut down time could therefore be up to 1.0 seconds for these technologies. RLC is adjusted to min. +/-1% of the inverter rated output power</p> <p>1) P_{EUT}: EUT output power 2) P_{AC}: Real power flow at S1 in Figure 1. Positive means power from EUT to utility. Nominal is the 0 % test condition value. 3) Q_{AC}: Reactive power flow at S1 in Figure 1. Positive means power from EUT to utility. Nominal is the 0 % test condition value. 4) BL: Balance condition, IB: Imbalance condition. Condition A: EUT output power $P_{EUT} = \text{Maximum}^{5)}$ EUT input voltage $^{6)} = >90\%$ of rated input voltage range 5) Maximum EUT output power condition should be achieved using the maximum allowable input power. Actual output power may exceed nominal rated output. 6) Based on EUT rated input operating range. For example, If range is between X volts and Y volts, 90 % of range = $X + 0,9 \times (Y - X)$. Y shall not exceed $0,8 \times$ EUT maximum system voltage (i.e., maximum allowable array open circuit voltage). In any case, the EUT should not be operated outside of its allowable input voltage range.</p>									

The results refer to the original test report PVUK140508N005 issued by Bureau Veritas Shenzhen Co., Ltd. Dongguan Branch, dated on Jul. 22, 2014.

Disconnection at P_{AC} 0% and Q_{AC} 0% reactive load and 100% nominal power

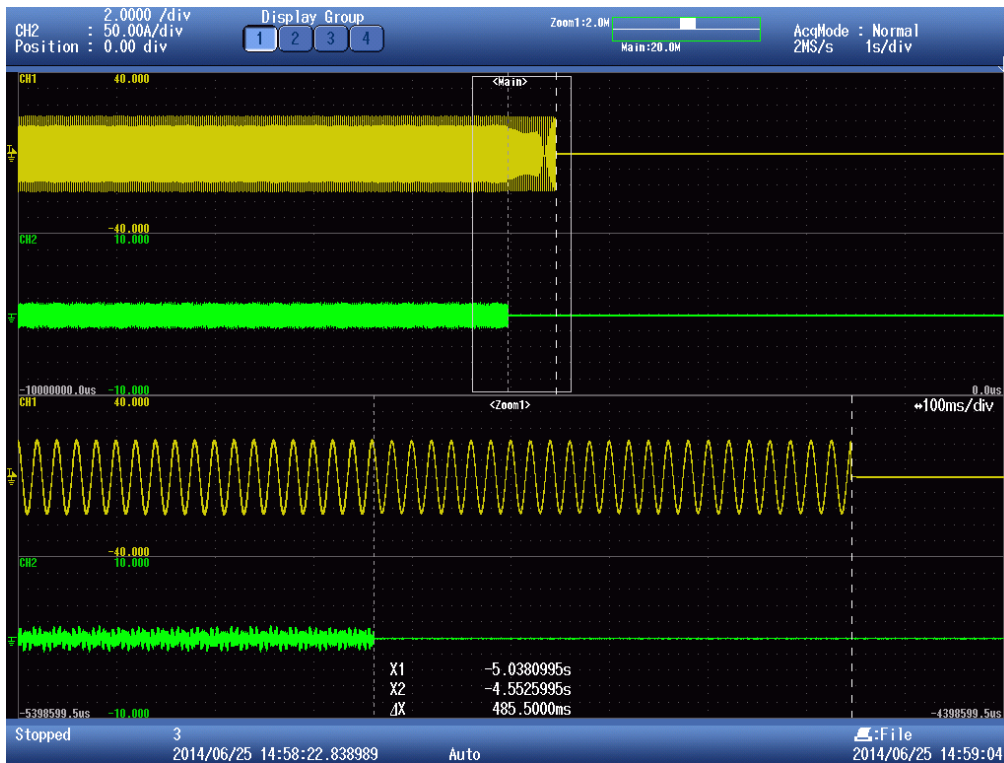

Note:
C1: EUT Current
C2: Fundamental of I_{AC}

A1.3.4 Loss of mains protection according BS EN 62116									P
The requirement is specified in section 10.2, test procedure in Annex A.2.2.4 Load imbalance (real, reactive load) for test condition A (EUT output = 50 % – 66 %)									
SOFAR 3000TL									
Test conditions		Frequency: 50+/-0,1Hz U _N =230+/-3Vac Distortion factor of chokes < 2% Quality =1							
Disconnection limit		0,5s							
No	P _{EUT} ¹⁾ (% of EUT rating)	Reactive load (% of Q _L in 6.1.d) 1)	P _{AC} ²⁾ (% of nominal)	Q _{AC} ³⁾ (% of nominal)	P _{EUT} [W per phase]	V _{DC} [V]	Q _f [1]	Run on Time [ms]	Remarks ⁴⁾
32	66	66	0	-6	1771	315	0,97	95	
12	66	66	0	-5	1771	315	0,98	116	Test B at IB
13	66	66	0	-4	1771	315	0,98	95	Test B at IB
14	66	66	0	-3	1771	315	0,99	131	Test B at IB
15	66	66	0	-2	1771	315	0,99	150	Test B at IB
16	66	66	0	-1	1771	315	1,00	233	Test B at IB
2	66	66	0	0	1771	315	1,00	477	Test B at BL
17	66	66	0	1	1771	315	1,01	200	Test B at IB
18	66	66	0	2	1771	315	1,01	387	Test B at IB
19	66	66	0	3	1771	315	1,02	165	Test B at IB
20	66	66	0	4	1771	315	1,02	217	Test B at IB
21	66	66	0	5	1771	315	1,03	139	Test B at IB
Parameter at 0%		L= 94,92 mH		R= 29,87 Ω		C= 106,93 μF			
Indicate additional shut down time included in above results. (Disconnection device operation time)								20ms	
<p>Note: RLC is adjusted to min. +/-1% of the inverter rated output power 1) P_{EUT}: EUT output power 2) P_{AC}: Real power flow at S1 in Figure 1. Positive means power from EUT to utility. Nominal is the 0 % test condition value. 3) Q_{AC}: Reactive power flow at S1 in Figure 1. Positive means power from EUT to utility. Nominal is the 0 % test condition value. 4) BL: Balance condition, IB: Imbalance condition. Condition B: EUT output power P_{EUT} = 50 % – 66 % of maximum EUT input voltage ⁵⁾ = 50 % of rated input voltage range, ±10 % 5) Based on EUT rated input operating range. For example, If range is between X volts and Y volts, 90 % of range = X + 0,5 × (Y – X). Y shall not exceed 0,8 × EUT maximum system voltage (i.e., maximum allowable array open circuit voltage). In any case, the EUT should not be operated outside of its allowable input voltage range.</p>									

The results refer to the original test report PVUK140508N005 issued by Bureau Veritas Shenzhen Co., Ltd. Dongguan Branch, dated on Jul. 22, 2014.

Disconnection at P_{AC} 0% and Q_{AC} 0% reactive load and 66% nominal power

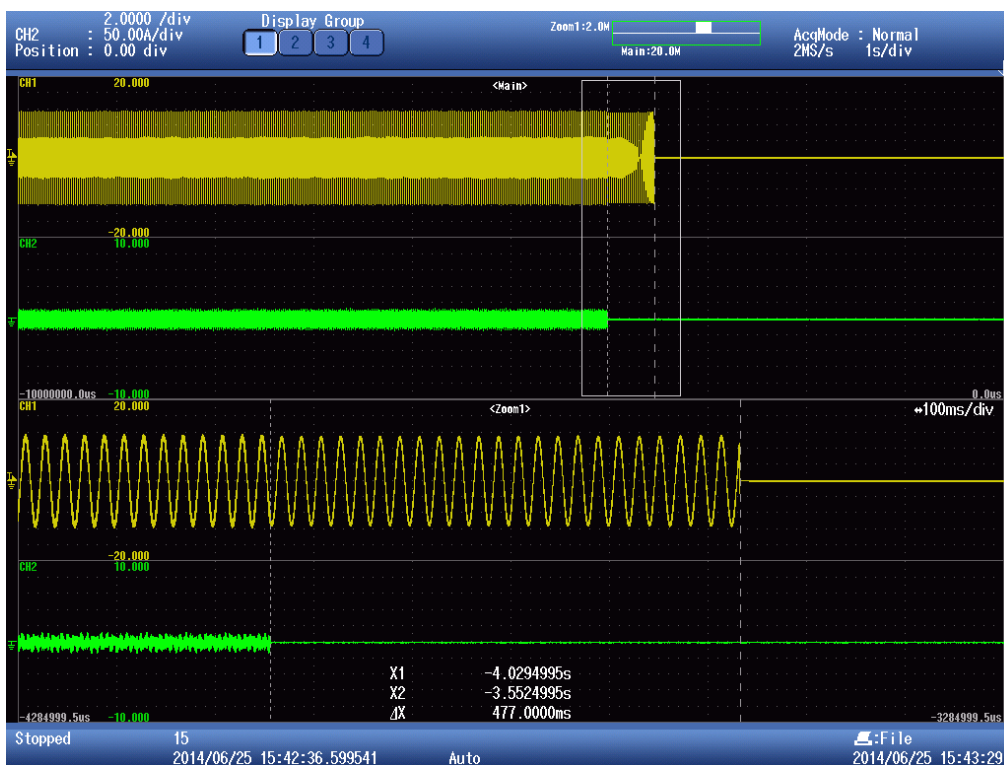

Note:
C1: EUT Current
C2: Fundamental of I_{AC}

A1.3.4 Loss of mains protection according BS EN 62116									P
The requirement is specified in section 10.2, test procedure in Annex A.2.2.4 Load imbalance (real, reactive load) for test condition A (EUT output = 25 % – 33 %)									
SOFAR 3000TL									
Test conditions		Frequency: 50+/-0,1Hz U _N =230+/-3Vac Distortion factor of chokes < 2% Quality =1							
Disconnection limit		0,5s							
No	P _{EUT} ¹⁾ (% of EUT rating)	Reactive load (% of Q _L in 6.1.d) 1)	P _{AC} ²⁾ (% of nominal)	Q _{AC} ³⁾ (% of nominal)	P _{EUT} [W per phase]	V _{DC} [V]	Q _f [1]	Run on Time [ms]	Remarks ⁴⁾
33	33	33	0	-6	828	247	0,97	88	
22	33	33	0	-5	828	247	0,98	213	Test B at IB
23	33	33	0	-4	828	247	0,98	72	Test B at IB
24	33	33	0	-3	828	247	0,99	136	Test B at IB
25	33	33	0	-2	828	247	0,99	222	Test B at IB
26	33	33	0	-1	828	247	1,00	408	Test B at IB
3	33	33	0	0	828	247	1,00	499	Test B at BL
27	33	33	0	1	828	247	1,01	304	Test B at IB
28	33	33	0	2	828	247	1,01	184	Test B at IB
29	33	33	0	3	828	247	1,02	218	Test B at IB
30	33	33	0	4	828	247	1,02	100	Test B at IB
31	33	33	0	5	828	247	1,03	69	Test B at IB
Parameter at 0%		L= 202,14 mH		R= 63,89 Ω		C= 50,00 μF			
Indicate additional shut down time included in above results. (Disconnection device operation time)								20ms	
<p>Note: RLC is adjusted to min. +/-1% of the inverter rated output power 1) P_{EUT}: EUT output power 2) P_{AC}: Real power flow at S1 in Figure 1. Positive means power from EUT to utility. Nominal is the 0 % test condition value. 3) Q_{AC}: Reactive power flow at S1 in Figure 1. Positive means power from EUT to utility. Nominal is the 0 % test condition value. 4) BL: Balance condition, IB: Imbalance condition. Condition C: EUT output power P_{EUT} = 25 % – 33 %⁵⁾ of maximum EUT input voltage⁶⁾ = <10 % of rated input voltage range 5) Or minimum allowable EUT output level if greater than 33 %. 6) Based on EUT rated input operating range. For example, If range is between X volts and Y volts, 90 % of range = X + 0,1 × (Y – X). Y shall not exceed 0,8 × EUT maximum system voltage (i.e., maximum allowable array open circuit voltage). In any case, the EUT should not be operated outside of its allowable input voltage range.</p>									

The results refer to the original test report PVUK140508N005 issued by Bureau Veritas Shenzhen Co., Ltd. Dongguan Branch, dated on Jul. 22, 2014.

Disconnection at P_{AC} 0% and Q_{AC} 0% reactive load and 33% nominal power

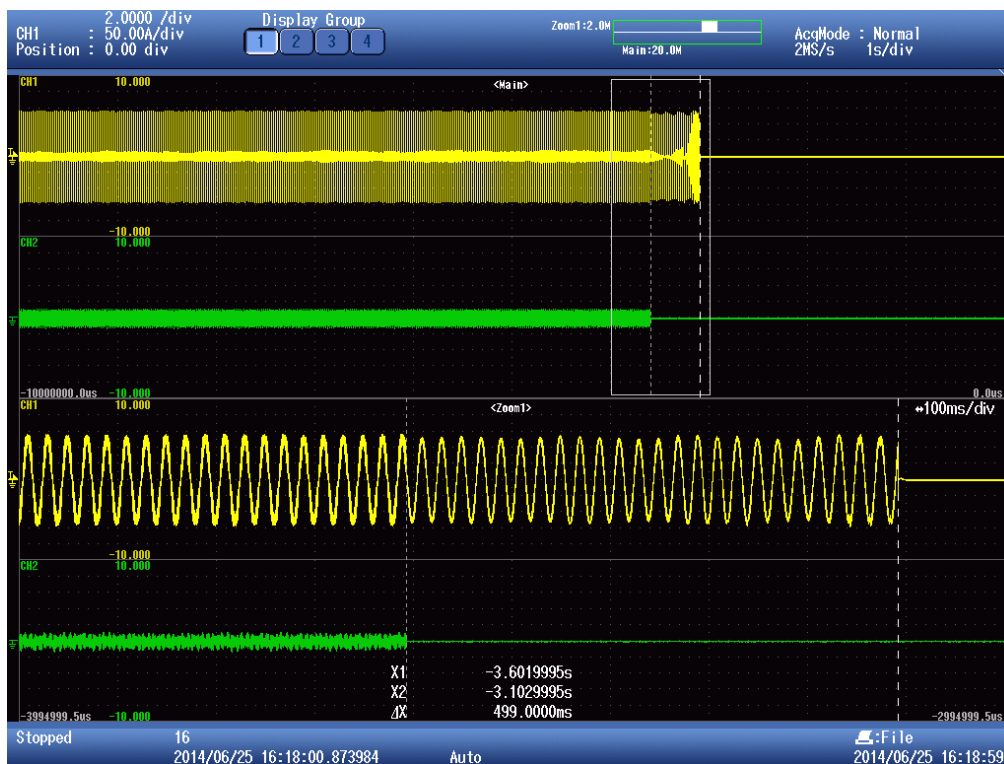

Note:

C1: EUT Current
 C2: Fundamental of I_{AC}

A 1.2.5 Reconnection The test procedure in Annex A 1.2.5 (Inverter connected) or Annex A2 A 2.2.5 (Synchronous).			P	
Test should prove that the reconnection sequence starts after a minimum delay of 20 seconds for restoration of voltage and frequency to within the stage 1 settings of table 1.				
Under Voltage(182V)				
Time delay setting		Measured delay		
20s		78,6s		
Over Voltage(266,2V)				
Time delay setting		Measured delay		
20s		78,9s		
Under Frequency(47,4Hz)				
Time delay setting		Measured delay		
20s		78,6s		
Over Frequency(52,1Hz)				
Time delay setting		Measured delay		
20s		79,0s		
Checks on no reconnection when voltage or frequency is brought to just outside stage 1 limits of table 1.				
	At 266,2V	At 182V	At 47,4Hz	At 52,1Hz
Confirmation that the SSEG does not re-connect.	No reconnection	No reconnection	No reconnection	No reconnection
Note: The tests had been performed on the SOFAR 3000TL is valid for the SOFAR 1100TL, SOFAR 1600TL, SOFAR 2200TL and SOFAR 2700TL, since it is same as in hardware and just power derated by software.				

A1.2.6 Frequency Drift and Step change Stability test				P
The requirement is specified in section 11.3, test procedure in Annex A.1.2.6 (Inverter connected) or Annex A2 A.2.2.6 (Synchronous).				
	Start Frequency	Change	End Frequency	Confirm no trip
Positive Vector Shift	49,0Hz	+50 degrees		No trip
Negative Vector Shift	50,0Hz	-50 degrees		No trip
Positive Frequency drift	49,0Hz	+0,95Hz/sec	51,0Hz	No trip
Negative Frequency drift	51,0Hz	-0,95Hz/sec	49,0Hz	No trip

Note:
Manufacturers considering new designs should allow for the RoCoF where stability is required to be increased to, up to 2Hz per second, as proposed in the new European network codes, which are expected to come into force over the period 2014/2015. Under these conditions RoCoF will cease to be an effective loss of mains protection and is unlikely to be permitted in future revisions of this document.

For the step change test the SSEG should be operated with a measureable output at the start frequency and then a vector shift should be applied by extending or reducing the time of a single cycle with subsequent cycles returning to the start frequency. The start frequency should then be maintained for a period of at least 10 seconds to complete the test. The SSEG should not trip during this test.

For frequency drift tests the SSEG should be operated with a measureable output at the start frequency and then the frequency changed in a ramp function at 0,95Hz per second to the end frequency. On reaching the end frequency it should be maintained for a period of at least 10 seconds. The SSEG should not trip during this test.

The tests had been performed on the SOFAR 3000TL is valid for the SOFAR 1100TL, SOFAR 1600TL, SOFAR 2200TL and SOFAR 2700TL, since it is same as in hardware and just power derated by software.

A 1.2.7 Active power feed-in at under-frequency

This test should be carried out in accordance with EN 50438 Annex D.3.2 active power feed-in at under-frequency.

P

Graph of frequency a) to b) to c):

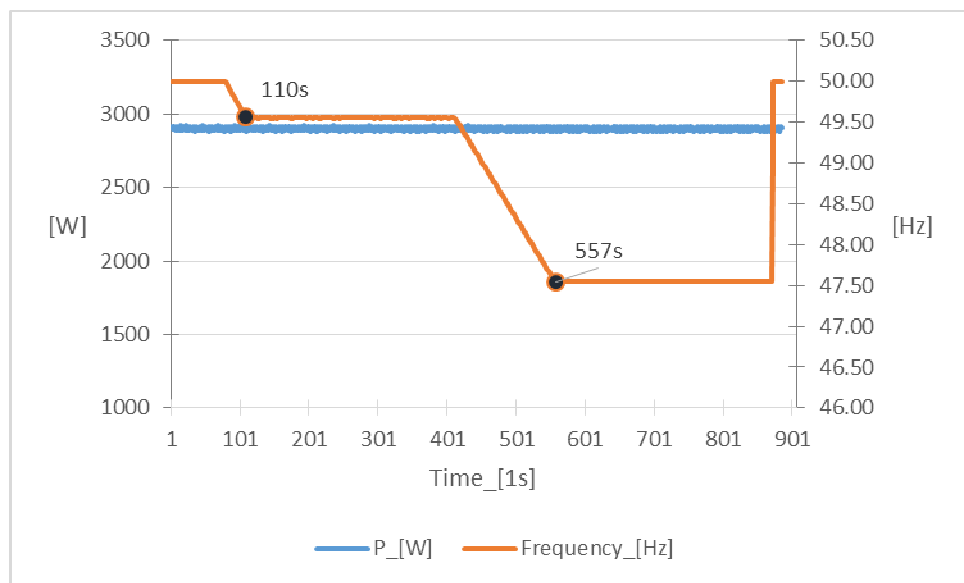

Test:

	Switch to:		
5-min mean value (each)	a) $50 \pm 0,01$ [Hz]	b) - 0,4 to - 0,5 [Hz]	c) - 2,4 to - 2,5 [Hz]
Frequency [Hz]:	50,00	49,55	47,55
Active power [kW]:	2,903	2.902	2,899
$\Delta P/P_M$ [%] per 1 Hz:			0,16

Test:

Operating points b) and c) must be kept for at least 5 minutes.

The test must be carried out at 100% P_n .

With a programmable AC source, the PGU is operated at 100% P_n and $50 \pm 0,01$ Hz, thereafter the frequency is reduced by 1 Hz/min. to - 0,4 to - 0,5 Hz and in addition to - 2,4 to - 2,5 Hz. A 5-min mean value is recorded both before and after the frequency change.

Assessment criterion:

The test is passed when the micro-generator

- does not disconnect from the network on a network frequency change at the operating points a) to c),
- continues to feed in 100% P_n in b) and
- the power reduction in point c) is less or equal to the power reduction of 10 % P_M per 1 Hz drop.

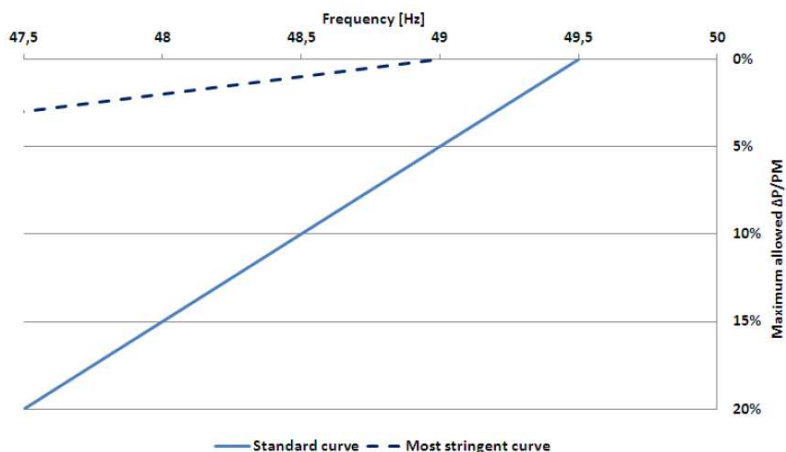

Maximum allowable power reduction in case of under-frequency

Note:

The tests had been performed on the SOFAR 3000TL is valid for the SOFAR 1100TL, SOFAR 1600TL, SOFAR 2200TL and SOFAR 2700TL, since it is same as in hardware and just power derated by software.

<p>A 1.2.8 Power response to over-frequency This test should be carried out in accordance with EN 50438 Annex D.3.3 Power response to over- frequency. The test should be carried out using the specific threshold frequency of 50.4 Hz and Droop of 10%.</p>	p
---	---

Test:

1-min mean value [Hz]:	a) 50,00	b) 50,45	c) 50,70	d) 51,15	e) 50,70	f) 50,45	g) 50,00
------------------------	----------	----------	----------	----------	----------	----------	----------

1. Measurement a) to g): Active power output > 80% P_n

Frequency [Hz]:	50,00	50,45	50,70	51,15	50,70	50,45	50,00
P _M [W]:	N/A	3007,45	2855,56	2582,15	2855,56	3007,45	N/A
P _{E60} [W]:	3037,83	3004,88	2857,41	2602,59	2857,32	3004,96	3037,95
ΔP _{E60} /P _M [%]:	N/A	0,09	-0,06	-0,68	-0,06	0,08	N/A
Active Power Gradient	N/A	9,22	10,10	10,47	10,10	9,24	N/A

2. Measurement a) to g): Active power output 40% and 60% after freezing > 80% P_n

Frequency [Hz]:	50,00	50,45	50,70	51,15	50,70	50,45	50,00
P _M [W]:	N/A	1498,69	1422,99	1286,75	1422,99	1498,69	N/A
P _{E60} [W]:	1513,82	1497,85	1423,06	1294,62	1425,95	1498,68	1511,18
ΔP _{E60} /P _M [%]:	N/A	0,03	0,01	-0,26	-0,10	0,01	N/A
Active Power Gradient	N/A	9,48	10,01	10,36	10,34	10,00	N/A

Limit ΔP/P_{1min}: 2,5 % of P_M

Graph of Measurement 1.: Active power output > 80% P_n

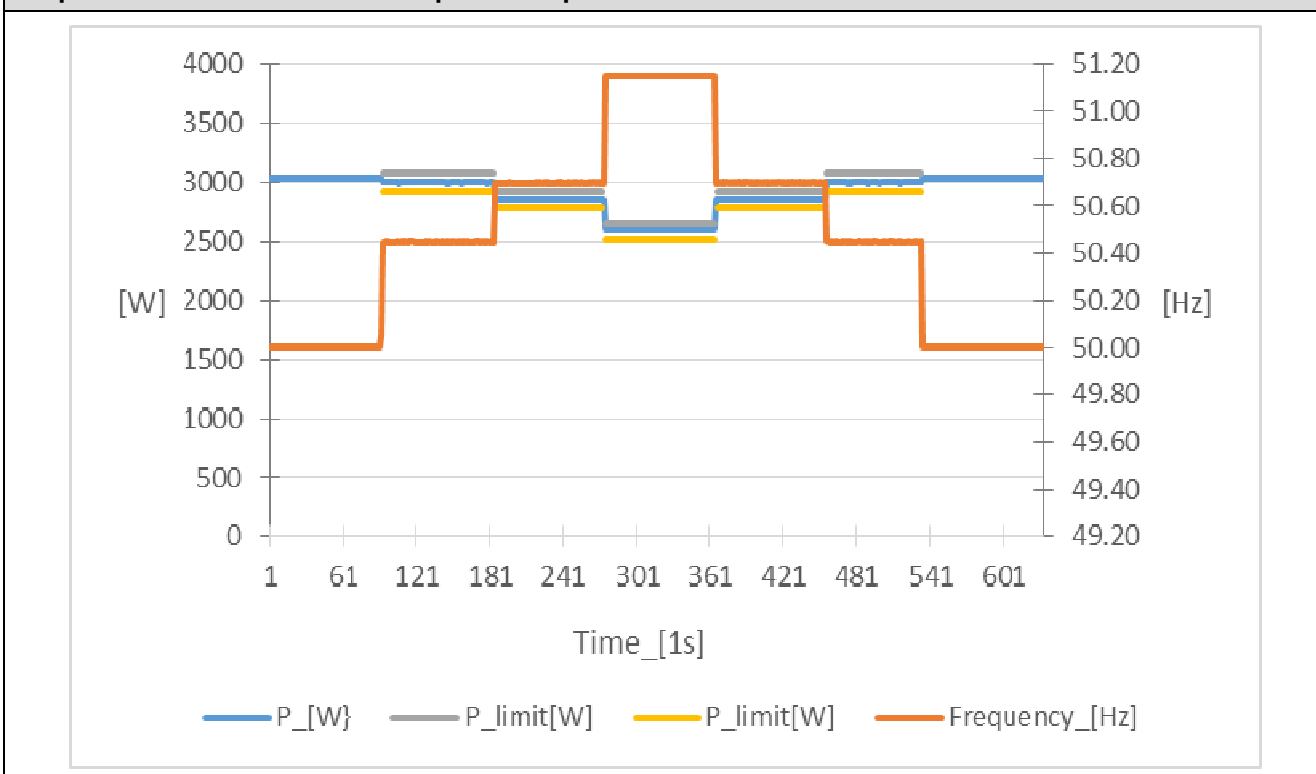

Graph of Measurement 2.:Active power output 40% and 60% after freezing > 80% P_n

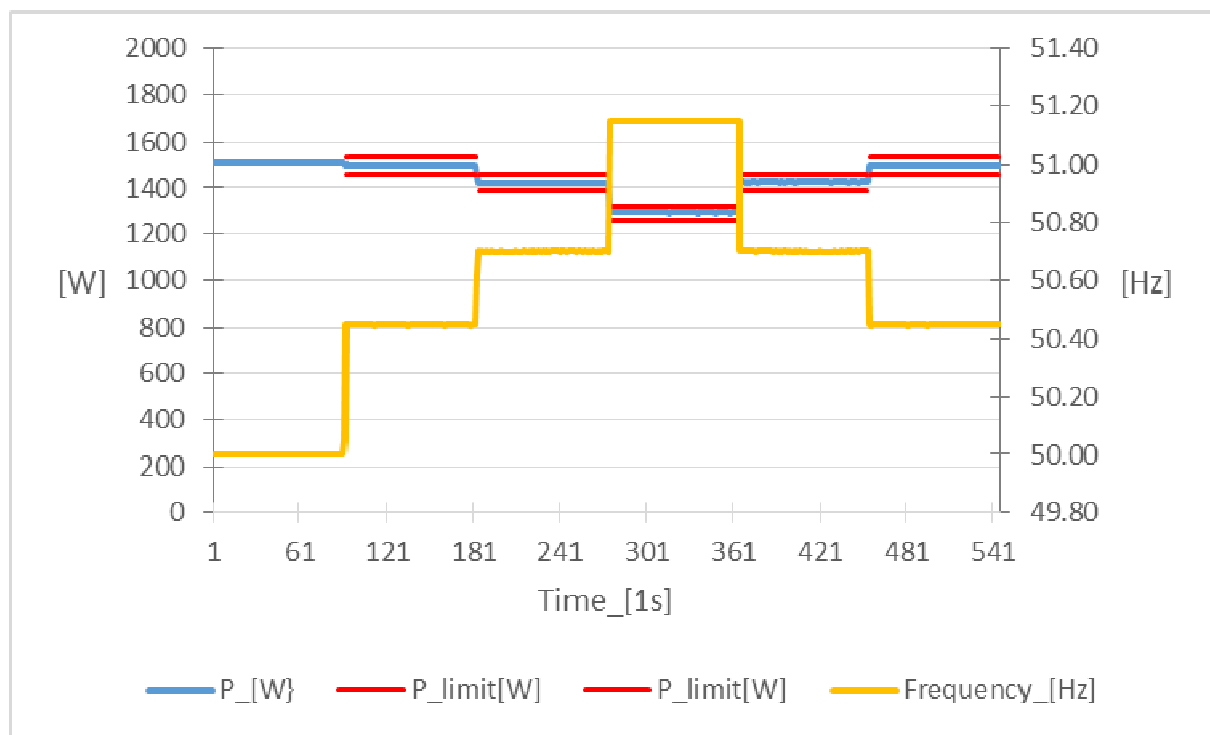

Graph of power gradient:

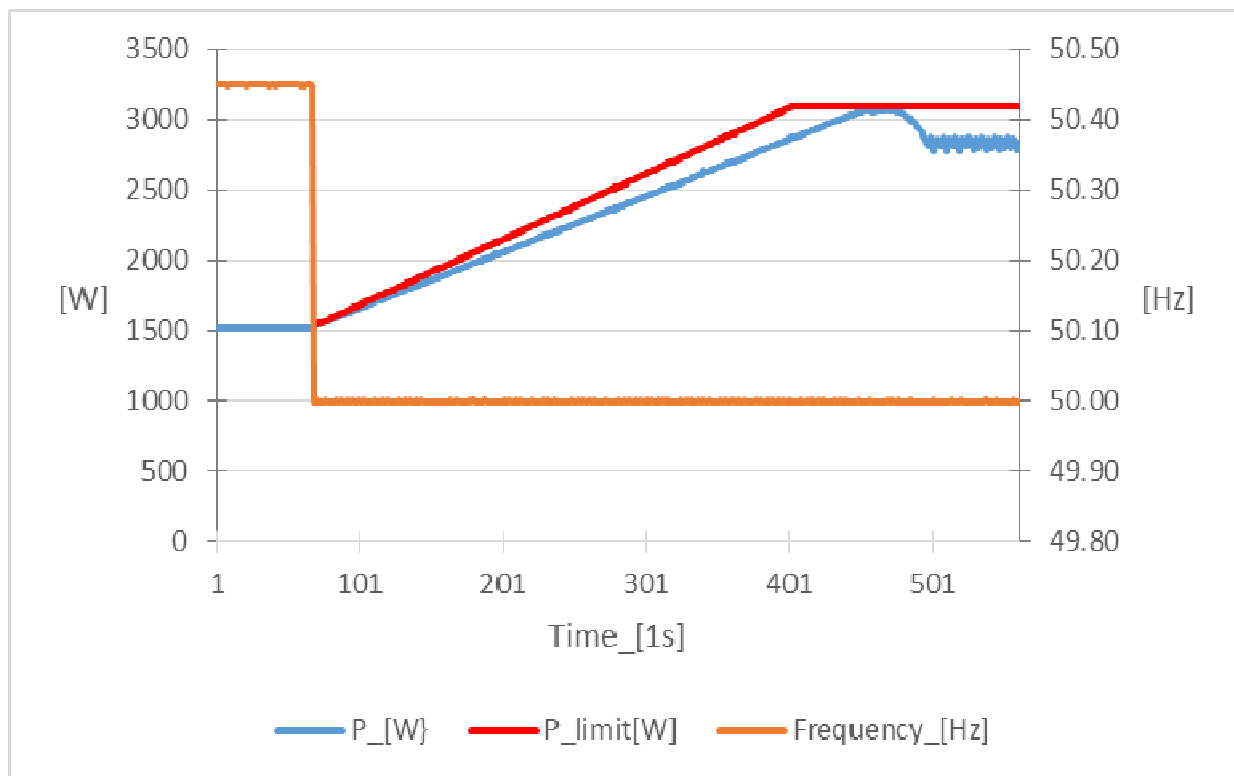

Test:

The test is conducted for two powers. First, the test must start at a power $> 80\% P_n$ ("Measurement 1"), and in a second test, for a power between 40% to $60\% P_n$ ("Measurement 2"). In the second test, after freezing of the P_M , the available active power output must be increased to a value $> 80\% P_n$, and after the network frequency of $50,2$ Hz is fallen below, the rise of the active power gradient must be recorded.

Point g) must be held until the micro-generator is again feeding in with the active power output available.

Assessment criterion:

For $f = 50,2$ Hz, the value of the P_M active power currently being generated is "frozen".

a) For adjustable micro-generators when:

1) the active power reduces between measuring points b) and f) given above with the set gradient P_M per Hz for a increasing frequency (or rises for a frequency decreasing again).

2) the maximum active power gradient occurring in point is less than the configured maximum active power per minute

3) the reaction value of the setpoint determined by the gradient characteristic curve does not differ from P_n by more than $\pm 10\%$.

4) the settling time is equal or below 2 s with an intentional delay set to zero

b) For partly adjustable micro-generators

1) when they behave as in a) within their adjustment range, and

2) when, outside the adjustable range, the power fed in on leaving the adjustment range remains constant until shutdown. Shutdown must be no later than at $51,5$ Hz.

Note:

The tests had been performed on the SOFAR 3000TL is valid for the SOFAR 1100TL, SOFAR 1600TL, SOFAR 2200TL and SOFAR 2700TL, since it is same as in hardware and just power derated by software.

A1.3.1 Harmonic Current Emissions						P
The test requirements are specified in Annex A1 A.1.3.1 (Inverter connected) or Annex A2 A.2.3.1 (Synchronous).						
SOFAR 1100TL						
SSEG rating per phase (rpp)					NV=MV*3,68/rpp	
	At 45-55% of rated output 0,5kW		100% of rated output 1,0kW			
Harmonic	Measured Value (MV) in Amps	Normalised Value (NV) in Amps	Measured Value (MV) in Amps	Normalised Value (NV) in Amps	Limit in BS EN61000-3-2 in Amps	Higher limit for odd harmonics 21 and above
2nd	0,009	0,032	0,002	0,006	1,080	
3rd	0,050	0,180	0,080	0,293	2,300	
4th	0,005	0,019	0,001	0,005	0,430	
5th	0,014	0,049	0,010	0,036	1,140	
6th	0,004	0,014	0,001	0,005	0,300	
7th	0,013	0,046	0,006	0,023	0,770	
8th	0,003	0,012	0,002	0,006	0,230	
9th	0,008	0,030	0,004	0,015	0,400	
10th	0,004	0,013	0,002	0,007	0,184	
11th	0,005	0,019	0,003	0,010	0,330	
12th	0,003	0,011	0,002	0,007	0,153	
13th	0,004	0,013	0,002	0,007	0,210	
14th	0,003	0,010	0,002	0,007	0,131	
15th	0,003	0,011	0,002	0,007	0,150	
16th	0,002	0,008	0,002	0,006	0,115	
17th	0,003	0,010	0,002	0,006	0,132	
18th	0,002	0,007	0,001	0,005	0,102	
19th	0,002	0,008	0,002	0,006	0,118	
20th	0,002	0,006	0,001	0,005	0,092	
21th	0,003	0,010	0,002	0,008	0,107	0,160
22th	0,002	0,006	0,001	0,004	0,084	
23th	0,002	0,007	0,002	0,006	0,098	0,147
24th	0,001	0,005	0,001	0,004	0,077	
25th	0,002	0,007	0,002	0,007	0,090	0,135
26th	0,001	0,005	0,001	0,003	0,071	
27th	0,002	0,008	0,002	0,006	0,083	0,124
28th	0,001	0,005	0,001	0,004	0,066	
29th	0,002	0,007	0,002	0,007	0,078	0,117
30th	0,001	0,004	0,001	0,002	0,061	
31th	0,002	0,006	0,001	0,005	0,073	0,109
32th	0,002	0,006	0,001	0,003	0,058	
33th	0,002	0,007	0,002	0,006	0,068	0,102
34th	0,001	0,004	0,001	0,002	0,054	
35th	0,001	0,004	0,001	0,005	0,064	0,096
36th	0,001	0,005	0,001	0,002	0,051	
37th	0,002	0,008	0,002	0,006	0,061	0,091
38th	0,001	0,005	0,001	0,003	0,048	
39th	0,001	0,003	0,001	0,005	0,058	0,087
40th	0,001	0,004	0,001	0,002	0,046	

Note:
The higher limits for odd harmonics 21 and above are only allowable under certain conditions, if these higher limits are utilised please state the exemption used as detailed in part 6.2.3.4 of BS EN 61000-3-2 in the box below.

A1.3.1 Harmonic Current Emissions						P
The test requirements are specified in Annex A1 A.1.3.1 (Inverter connected) or Annex A2 A.2.3.1 (Synchronous).						
SOFAR 3000TL						
SSEG rating per phase (rpp)					NV=MV*3,68/rpp	
	At 45-55% of rated output 1,4kW		100% of rated output 2,8kW			
Harmonic	Measured Value (MV) in Amps	Normalised Value (NV) in Amps	Measured Value (MV) in Amps	Normalised Value (NV) in Amps	Limit in BS EN61000-3-2 in Amps	Higher limit for odd harmonics 21 and above
2nd	0,006	0,008	0,008	0,011	1,080	
3rd	0,080	0,105	0,158	0,208	2,300	
4th	0,002	0,003	0,006	0,008	0,430	
5th	0,035	0,046	0,032	0,042	1,140	
6th	0,003	0,004	0,003	0,004	0,300	
7th	0,014	0,019	0,014	0,018	0,770	
8th	0,003	0,004	0,003	0,004	0,230	
9th	0,007	0,009	0,005	0,007	0,400	
10th	0,003	0,004	0,004	0,006	0,184	
11th	0,006	0,008	0,006	0,008	0,330	
12th	0,003	0,004	0,004	0,005	0,153	
13th	0,008	0,010	0,012	0,016	0,210	
14th	0,003	0,004	0,004	0,005	0,131	
15th	0,008	0,011	0,010	0,013	0,150	
16th	0,003	0,004	0,003	0,004	0,115	
17th	0,010	0,013	0,013	0,017	0,132	
18th	0,002	0,003	0,002	0,003	0,102	
19th	0,011	0,015	0,014	0,018	0,118	
20th	0,002	0,003	0,003	0,003	0,092	
21th	0,012	0,016	0,015	0,019	0,107	0,160
22th	0,002	0,002	0,002	0,002	0,084	
23th	0,014	0,018	0,014	0,018	0,098	0,147
24th	0,002	0,002	0,002	0,002	0,077	
25th	0,013	0,016	0,013	0,017	0,090	0,135
26th	0,002	0,002	0,002	0,002	0,071	
27th	0,012	0,016	0,013	0,017	0,083	0,124
28th	0,002	0,002	0,002	0,002	0,066	
29th	0,012	0,015	0,012	0,016	0,078	0,117
30th	0,001	0,002	0,001	0,002	0,061	
31th	0,012	0,015	0,011	0,014	0,073	0,109
32th	0,001	0,002	0,001	0,002	0,058	
33th	0,012	0,015	0,009	0,012	0,068	0,102
34th	0,001	0,002	0,001	0,002	0,054	
35th	0,011	0,014	0,009	0,012	0,064	0,096
36th	0,002	0,002	0,001	0,001	0,051	
37th	0,010	0,014	0,008	0,010	0,061	0,091
38th	0,001	0,002	0,001	0,002	0,048	
39th	0,009	0,012	0,008	0,010	0,058	0,087
40th	0,001	0,002	0,001	0,002	0,046	

Note:
The higher limits for odd harmonics 21 and above are only allowable under certain conditions, if these higher limits are utilised please state the exemption used as detailed in part 6.2.3.4 of BS EN 61000-3-2 in the box below.
The tests had been performed on the SOFAR 1100TL and SOFAR 3000TL are valid for the SOFAR 1600TL, SOFAR 2200TL and SOFAR 2700TL, since it is same as in hardware and just power derated by software.

A1.3.2 Power factor				
The requirement is specified in section 9.5, test procedure in Annex A1 A.1.3.2 (Inverter connected) or Annex A2 A.2.3.2 (Synchronous).				
SOFAR 1100TL				
Output power	216,2 V	230 V	253 20 V	
20%	0,9696	0,9601	0,9573	Measured at three voltage levels and at full output. Voltage to be maintained within $\pm 1.5\%$ of the stated level during the test.
50%	0,9934	0,9914	0,9879	
75%	0,9969	0,9961	0,9943	
100%	0,9982	0,9978	0,9968	
Limit	>0,95	>0,95	>0,95	
SOFAR 3000TL				
Output power	216,2 V	230 V	253 20 V	
20%	0,9946	0,9932	0,9900	Measured at three voltage levels and at full output. Voltage to be maintained within $\pm 1.5\%$ of the stated level during the test.
50%	0,9992	0,9989	0,9984	
75%	0,9996	0,9994	0,9993	
100%	0,9997	0,9997	0,9995	
Limit	>0,95	>0,95	>0,95	
<p>Note: The power factor capability of the SSEG shall conform to EN 50438. When operating at Registered Capacity the SSEG shall operate at a power factor within the range 0.95 lagging to 0.95 leading relative to the voltage waveform unless otherwise agreed with the DNO eg for power factor improvement.</p> <p>The test set up shall be such that the Inverter supplies full load to the DNO's Distribution System via the power factor (pf) meter and the variac as shown below in figure A5. The Inverter pf should be within the limits given in 5.6, for three test voltages 230 V -6%, 230V and 230 V +10%.</p> <p>he tests had been performed on the SOFAR 1100TL and SOFAR 3000TL are valid for the SOFAR 1600TL, SOFAR 2200TL and SOFAR 2700TL, since it is same as in hardware and just power derated by software.</p>				

A 1.3.3 Voltage Flicker				P	
The requirement is specified in section 5.4.2, test procedure in Annex A or B 1.4.3					
Test conditions:	Maximum permissible voltage fluctuation (expressed as a percentage of nominal voltage at 100 % power) and flicker as per EN 61000-3-3				
	Starting	Stopping		Running	
Limit	3,3%	3,3%		P _{st} =1,0	P _{It} =0,65
Test value	See below				
SOFAR 1100TL					
No.	dc[%]	dmax[%]	d(t)[ms]	Pst	
1	0.00	0.00	0.00	0.07	
2	0.00	0.00	0.00	0.07	
3	0.00	0.00	0.00	0.07	
4	0.00	0.00	0.00	0.07	
5	0.00	0.00	0.00	0.07	
6	0.00	0.00	0.00	0.07	
7	0.00	0.00	0.00	0.07	
8	0.00	0.00	0.00	0.07	
9	0.00	0.00	0.00	0.07	
10	0.00	0.00	0.00	0.07	
11	0.00	0.00	0.00	0.07	
12	0.00	0.00	0.00	0.07	
				P _{It}	
				0.07	
SOFAR 3000TL					
No.	dc[%]	dmax[%]	d(t)[ms]	Pst	
1	0.00	0.00	0.00	0.07	
2	0.00	0.00	0.00	0.07	
3	0.00	0.00	0.00	0.07	
4	0.00	0.00	0.00	0.07	
5	0.00	0.00	0.00	0.07	
6	0.00	0.00	0.00	0.07	
7	0.00	0.00	0.00	0.07	
8	0.00	0.00	0.00	0.07	
9	0.00	0.00	0.00	0.07	
10	0.00	0.00	0.00	0.07	
11	0.00	0.00	0.00	0.07	
12	0.00	0.00	0.00	0.07	
				P _{It}	
				0.07	

Note:

*The stationary deviance of dc% is more relevant than the dynamic deviance of d_{max} at starting and stopping.

Mains Impedance according EN61000-3-3: $R_{max} = 0,24\Omega$; $jX_{max} = 0,15\Omega @50Hz$ ($|Z_{max}| = 0,283 / 0,472 \Omega$)
For single phase inverter $Z_{max} + R_n$ and jX_n $R_n = 0,16\Omega$; $jX_n = 0,1\Omega$

Calculation of the maximum permissible grid impedance at the point of common coupling based on dc:
 $Z_{max} = Z_{ref} * 3,3\% / d_c(P_n)$

The tests should be based on the limits of the EN61000-3-3 for less than 16A.

The tests had been performed on the SOFAR 1100TL and SOFAR 3000TL are valid for the SOFAR 1600TL, SOFAR 2200TL and SOFAR 2700TL, since it is same as in hardware and just power derated by software.

The results refer to the original test report PVUK140508N005 issued by Bureau Veritas Shenzhen Co., Ltd. Dongguan Branch, dated on Jul. 22, 2014.

A.1.3.4 DC injection The test procedure in Annex A1 A.1.3.4 (Inverter connected) or Annex A2 A.2.3.4 (Synchronous).	P
---	----------

SOFAR 1100TL				
Test level power	20%	50%	75%	100%
Recorded value in Amps	9mA	8 mA	8 mA	9 mA
As % of rated AC current	0,18%	0,17%	0,17%	0,18%
Limit	0,25%	0,25%	0,25%	0,25%

Diagram of Permanent DC-injection

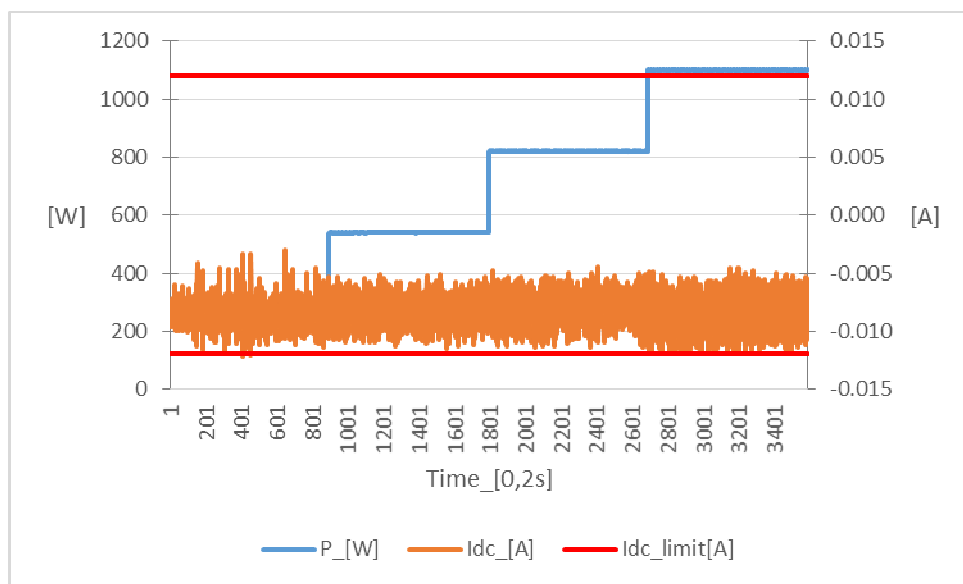

Test:
The level of DC injection from the Inverter-connected PV generator in to the DNO's Distribution System shall not exceed the levels specified in 5.5 when measured during operation at three levels, 20%, 50%, 75% and 100% of rating with a tolerance of plus or minus 5%.

SOFAR 3000TL				
Test level power	20%	50%	75%	100%
Recorded value in Amps	12,9mA	13,5 mA	4,8 mA	5,5 mA
As % of rated AC current	0,11%	0,11%	0,04%	0,05%
Limit	0,25%	0,25%	0,25%	0,25%

Diagram of Permanent DC-injection

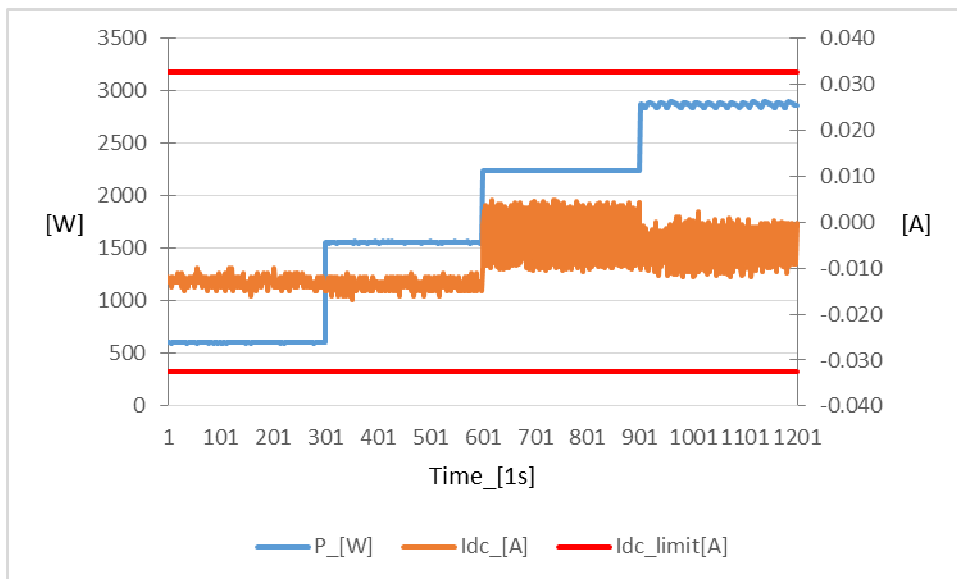

Note:

The tests had been performed on the SOFAR 1100TL and SOFAR 3000TL is valid for the SOFAR 1600TL, SOFAR 2200TL and SOFAR 2700TL, since it is same as in hardware and just power derated by software.

A 1.3.5 Short Circuit Current Contribution for Inverters

P

The test procedure in Annex A1 A.1.3.5 (Inverter connected) or Annex A2 A.2.3.5 (Synchronous).

For a directly coupled SSEG			For a Inverter SSEG		
Parameter	Symbol	Value	Time after fault	Volts	Amps
Peak Short Circuit current	i_p	N/A	20ms	49,9	12,77
Initial Value of aperiodic current	A	N/A	100ms	33,4	12,71
Initial symmetrical short-circuit current*	I_k	N/A	250ms	30,2	12,73
Decaying (aperiodic) component of short circuit current*	i_{DC}	N/A	500ms	29,1	12,74
Reactance/Resistance Ratio of source*	X/R	N/A	Time to trip	0,516s	In seconds

Testing:

Testing procedure: LVRT 10 – 15 % U_{NOM} with > 500 ms shall be recorded



Note:

The values of voltage and current should be recorded for a period of up to 1 second when the changeover switch should be returned to the normal position. The voltage and current at relevant times shall be recorded in the type test report including the time taken for the Inverter to trip.

The tests had been performed on the SOFAR 3000TL is valid for the SOFAR 1100TL, SOFAR 1600TL, SOFAR 2200TL and SOFAR 2700TL, since it is same as in hardware and just power derated by software.

The results refer to the original test report PVUK140508N005 issued by Bureau Veritas Shenzhen Co., Ltd. Dongguan Branch, dated on Jul. 22, 2014.

<p>A1.3.6 Self Monitoring – Solid state Disconnection The test procedure in Annex A1 A.1.3.6 (Inverter connected) or Annex A2 A.2.3.6 (Synchronous).</p>	<p>N/A</p>
<p>It has been verified that in the event of the solid state switching device failing to disconnect the SSEG, the voltage on the output side of the switching device is reduced to a value below 50 volts within 0.5 seconds.</p>	

<p>A 1.3.7 Electromagnetic Compatibility (EMC)</p>	<p>P</p>
<p>All equipment shall comply with the generic EMC standards: BS EN61000-6-3: 2007 Electromagnetic Compatibility, Generic Emission Standard; and BS EN61000-6-1: 2007 Electromagnetic Compatibility, Generic Immunity Standard.</p>	
<p>Note: The whole EMC test reports see Annex 1 EMC test report.</p>	

Annex No. 1

Pictures of the unit

Enclosure front view



Enclosure rear view



Enclosure bottom view



Internal view-1

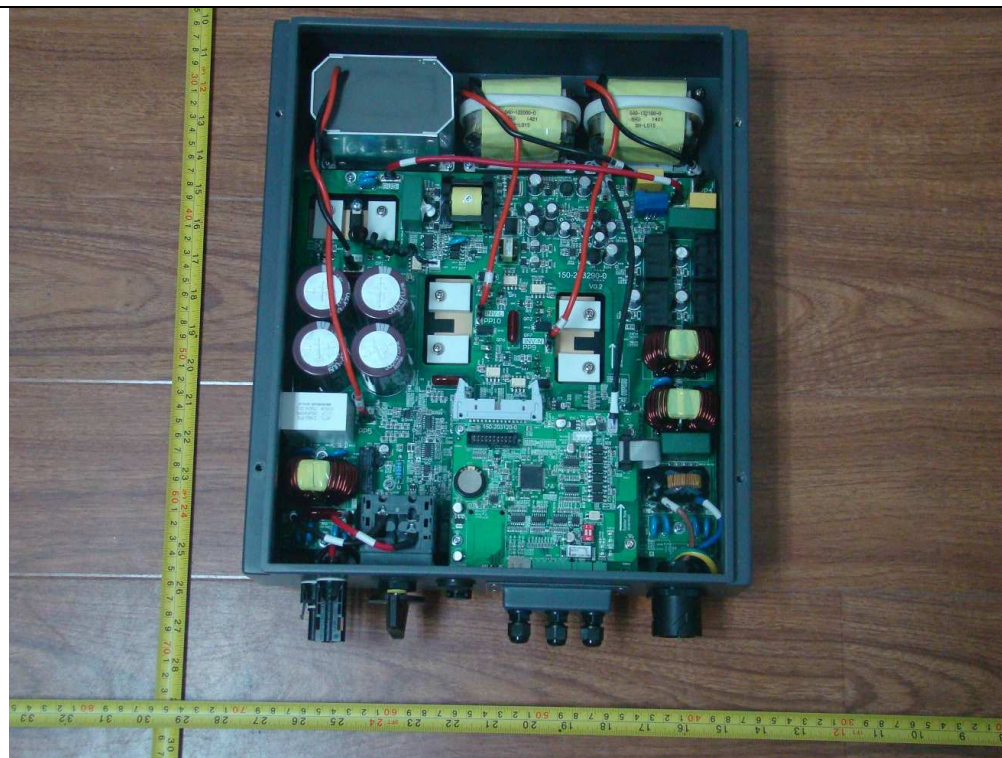

Internal view-2

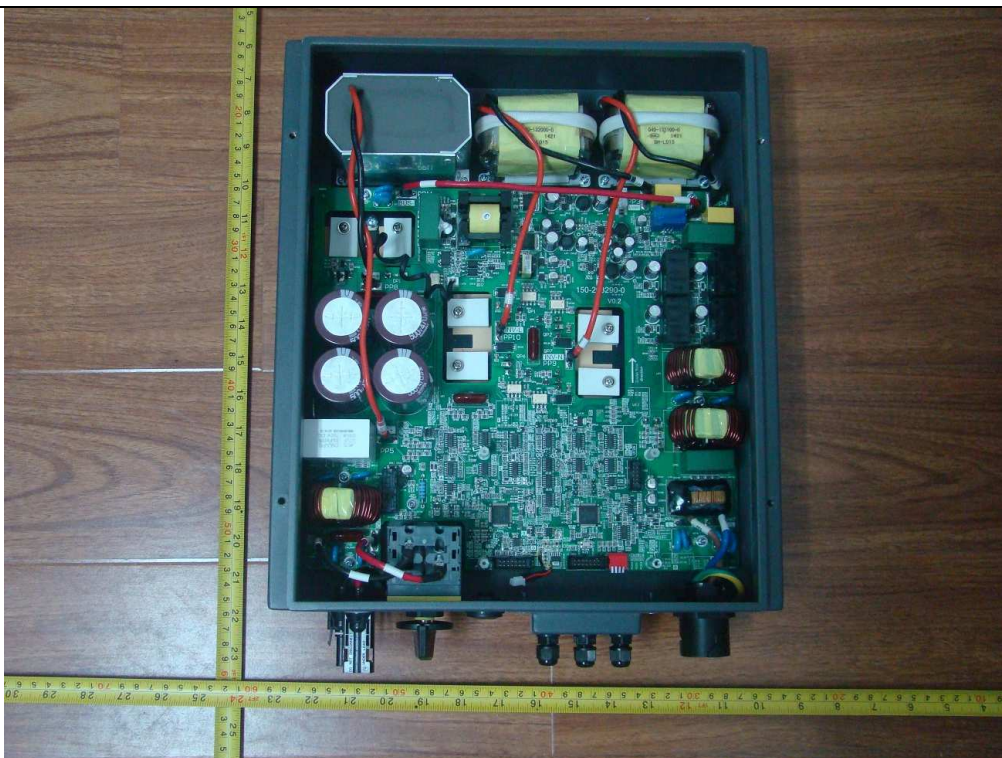

Internal view-3

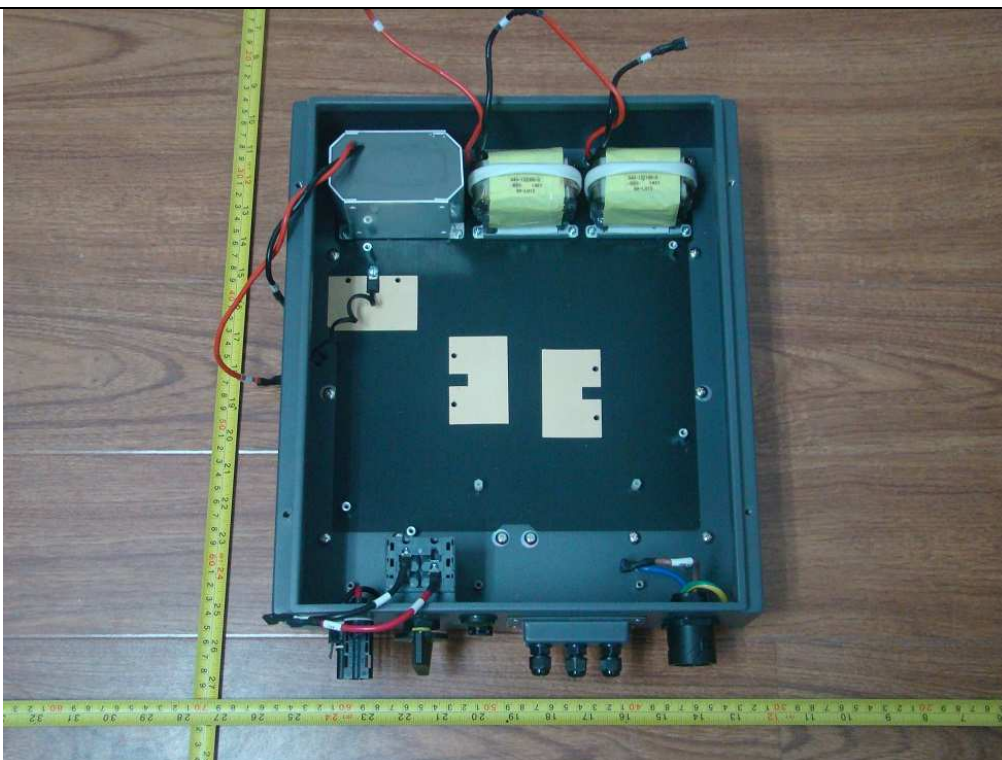

Internal view-4



Main power board component side view



Main power board solder side view

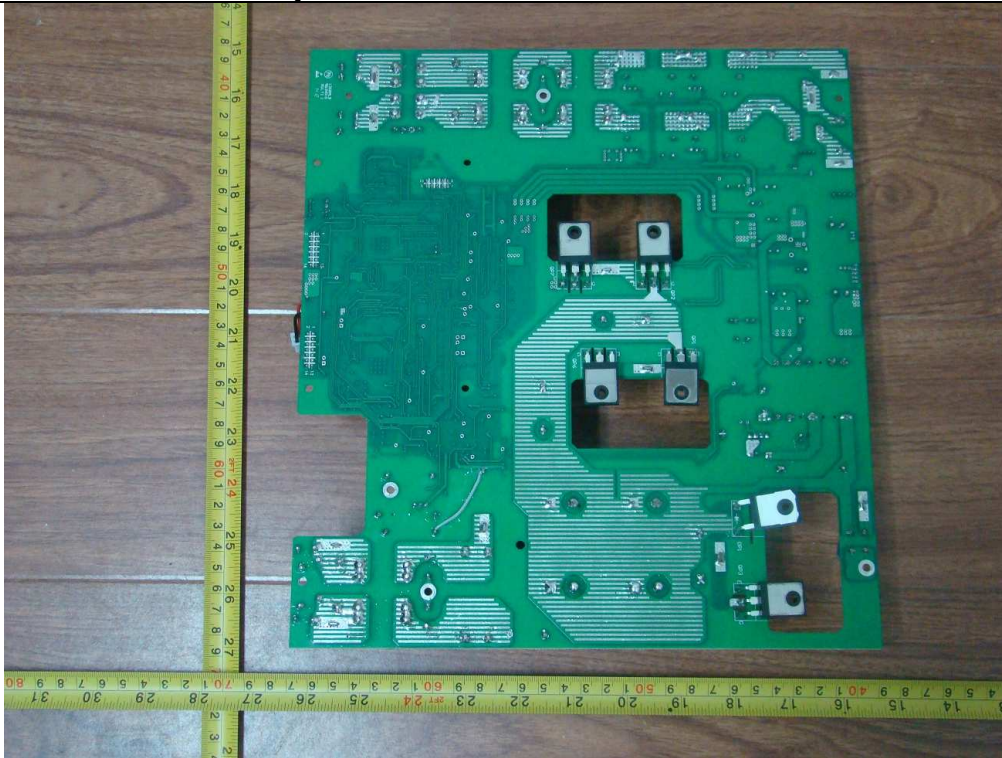

Control board component side view

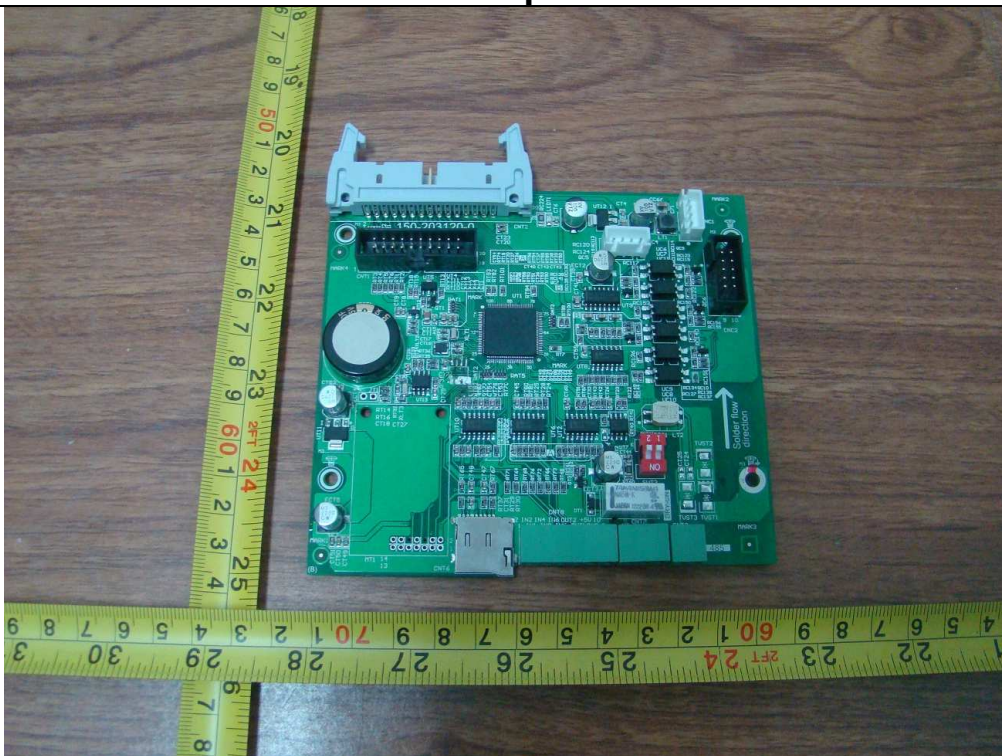

Control board solder side view

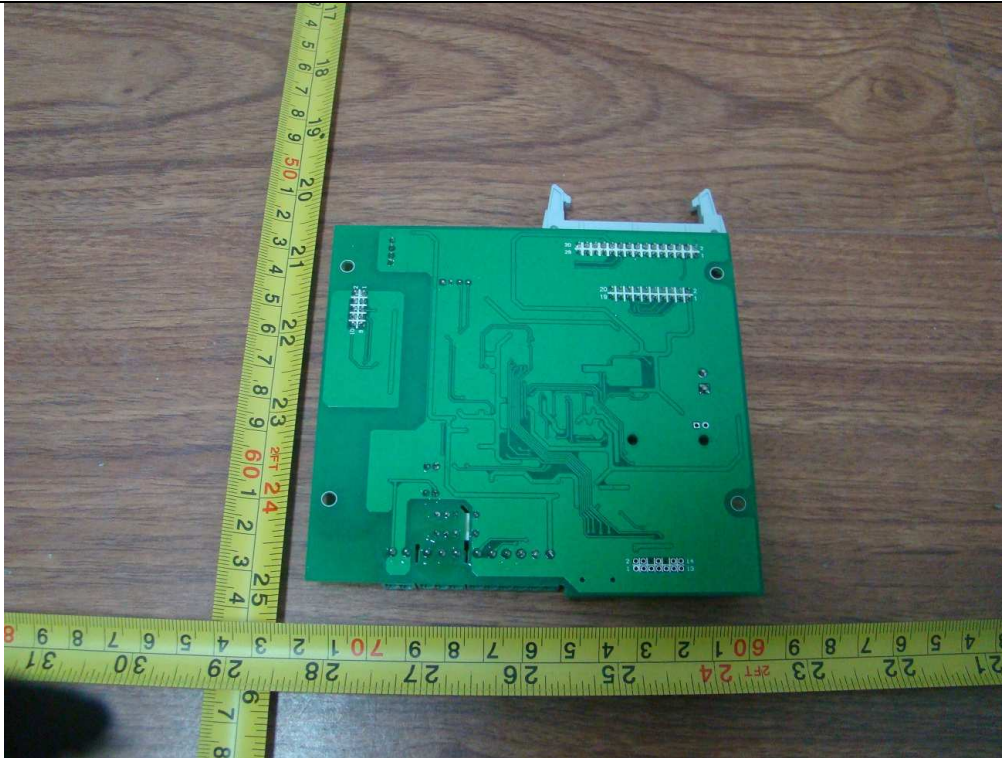

Display board component side view

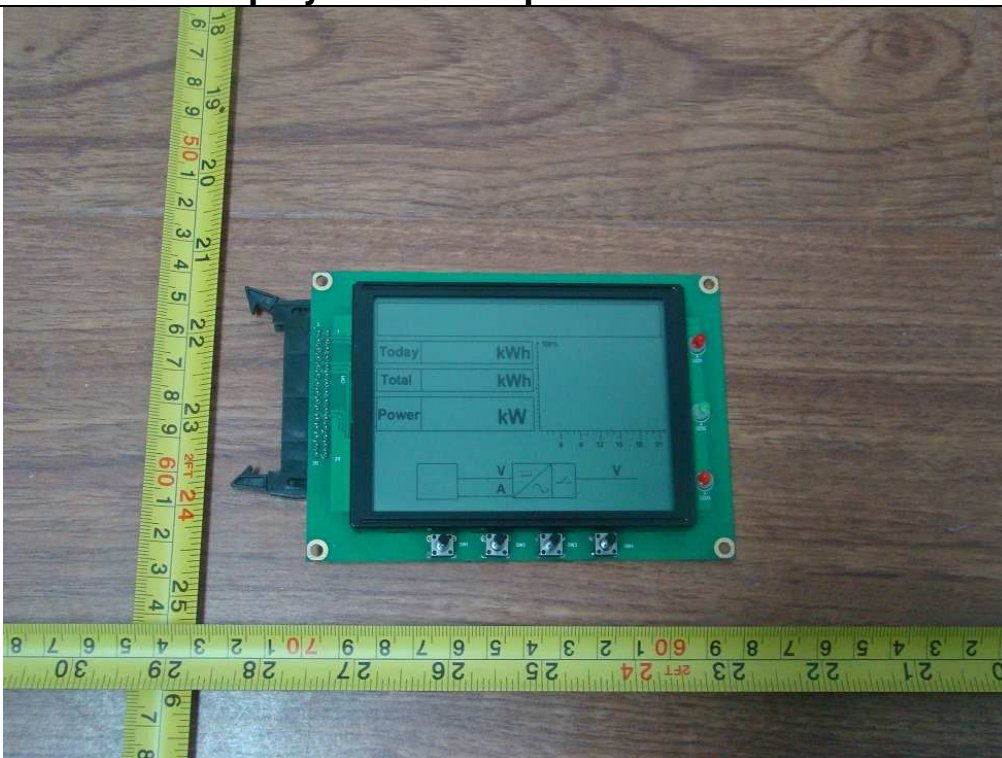

Display board solder side view

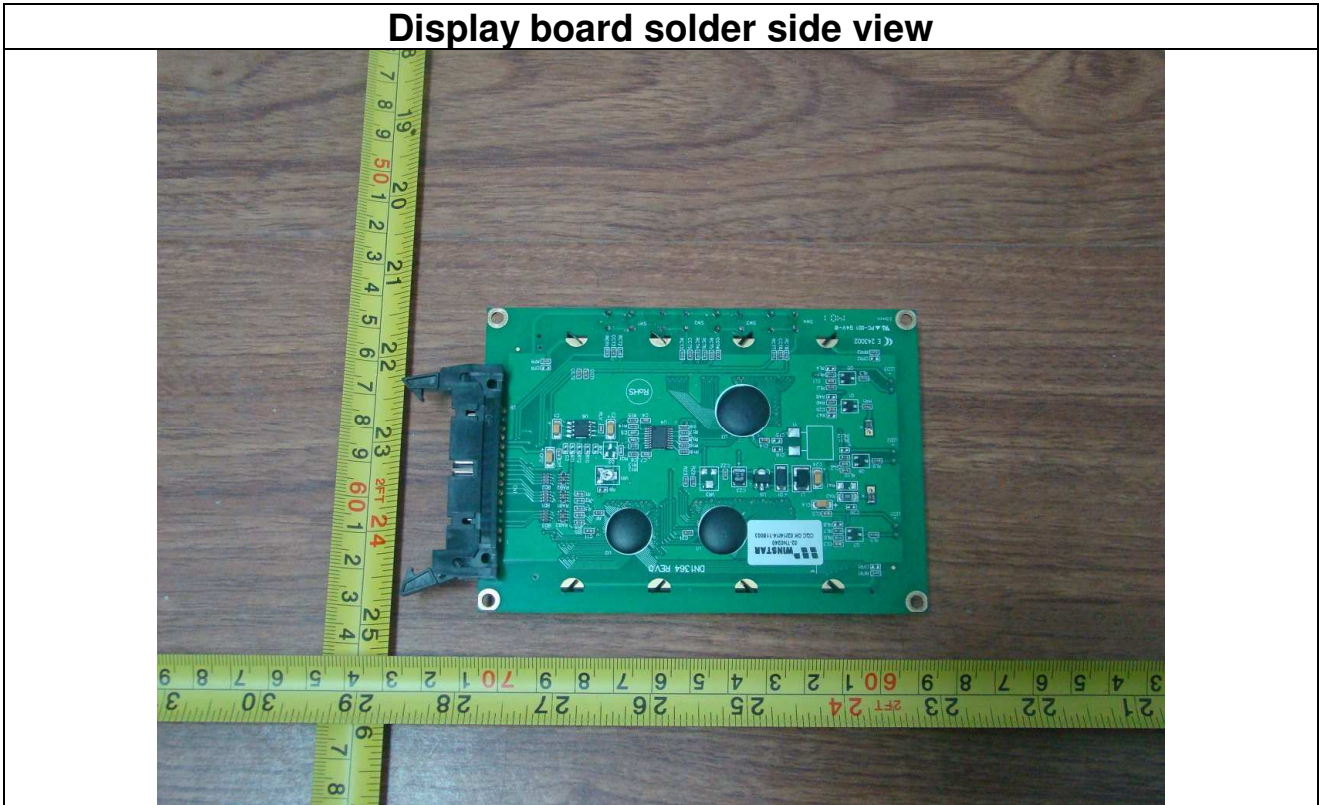



Annex No. 2

Test Equipment list

Test location: Bureau Veritas Shenzhen Co., Ltd. Dongguan Branch
Performed dates of test: 2019-01-11 to 2019-04-18

Equipment	Internal No.	Manufacturer	Type	Serial No.	Last Calibration
Power Analyzer	A4080002DG	YOKOGAWA	WT3000	91M210852	Dec. 13, 2018
AC Source	A7040019DG	Chroma	61512	61512000439	Monitored by Power Analyzer
AC Source	A7040020DG	Chroma	61512	61512000438	Monitored by Power Analyzer
DC Simulation Power Supply	A7040015DG	Chroma	62150H-1000S	62150EF00488	Monitored by Power Analyzer
DC Simulation Power Supply	A7040016DG	Chroma	62150H-1000S	62150EF00490	Monitored by Power Analyzer
Digital Phosphor Oscilloscope	A4089017DG	YOKOGAWA	DL850-H-HC	91N726247	Sep. 14, 2018
Isolation voltage probe	A1490008DG	YOKOGAWA	701901	//	Nov. 01, 2018
Current transducer	A1060009DG	YOKOGAWA	CT200	1130700019	Nov. 17, 2018

Test location: Bureau Veritas Shenzhen Co., Ltd. Dongguan Branch
Performed dates of test: 2019-09-22 to 2019-09-23

Equipment	Internal No.	Manufacturer	Type	Serial No.	Last Calibration
Power Analyzer	A4080002DG	YOKOGAWA	WT3000	91M210852	Dec. 13, 2018
AC Source	A7040019DG	Chroma	61512	61512000439	Monitored by Power Analyzer
AC Source	A7040020DG	Chroma	61512	61512000438	Monitored by Power Analyzer
DC Simulation Power Supply	A7040015DG	Chroma	62150H-1000S	62150EF00488	Monitored by Power Analyzer
DC Simulation Power Supply	A7040016DG	Chroma	62150H-1000S	62150EF00490	Monitored by Power Analyzer